

# INVITATION TO BID (ITB)

**Supply and Delivery of Rokovoka Evacuation Centre, Nalawa, Ra**

ITB Reference No:  
FJ2024/ITB01/001

Country: Fiji

Date: 26/03/2024

## SECTION 1: LETTER OF INVITATION

International Organization for Migration, hereinafter referred to as IOM, hereby invites prospective bidders to submit a bid in accordance with the General Conditions of Contract and the Schedule of Requirements as set out in this Invitation to Bid (ITB).

To enable you to submit a bid, please read the following attached documents carefully.

Section 1: This Letter of Invitation

Section 2: Instructions to Bidders

Section 3: Data Sheet

Section 4: Evaluation Criteria

Section 5: Schedule of Requirements

Section 6: Conditions of Contract and Contract Forms

Section 7: Bidding Forms

- Form A: Bid Confirmation
- Form B: Checklist
- Form C: Bid Submission
- Form D: Bidder Information
- Form E: Joint Venture/Consortium/Association Information
- Form F: Eligibility and Qualification
- Form G: Technical Bid
- Form H: Price Schedule

If you are interested in submitting a bid in response to this ITB, please prepare your bid in accordance with the requirements and procedure as set out in this ITB and submit it by the deadline for submission of bids set out in Section 3: Data Sheet.

Please acknowledge receipt of this ITB by completing and returning the attached Form A: Bid Confirmation by email to n/a. no later than n/a, indicating whether you intend to submit a bid or not. Should you require further clarifications, kindly communicate with the contact person/s identified in Section 3: Data Sheet as the focal point for queries on this ITB.

We look forward to receiving your bid.

Approved by:

---

Name: Shevneel Kumar

Title: Procurement and Logistic Asst

Date: 03/04/2024

## SECTION 2: INSTRUCTIONS TO BIDDERS

GENERAL	
<b>1. Scope</b>	<p>Bidders are invited to submit a bid for the goods/services/works specified in Section 5: Schedule of Requirements, in accordance with this Invitation to Bid (ITB). A summary of the scope of the bid is included in Section 3: Data Sheet.</p> <p>Bidders shall adhere to all the requirements of this ITB, including any amendment made in writing by IOM. This ITB is conducted in accordance with Policies and Procedures of IOM.</p>
<b>2. Interpretation of the ITB</b>	<p>Any bid submitted will be regarded as an offer by the bidder and does not constitute or imply the acceptance of the bid by IOM. IOM is under no obligation to award a contract to any bidder as a result of this ITB.</p>
<b>3. Supplier Code of Conduct</b>	<p>All prospective suppliers must read the UN Supplier Code of Conduct and acknowledge that it provides the minimum standards expected of suppliers to the UN. The Code of Conduct, which includes principles on labour, human rights, environment and ethical conduct may be found at: <a href="http://ungm.org">Supplier Code of Conduct (ungm.org)</a>.</p>
<b>4. Eligible bidders</b>	<p>Bidders shall have the legal capacity to enter into a binding contract with IOM.</p> <p>A bidder, and all parties constituting the bidder, may have the nationality of any country with the exception of the nationalities, if any, listed in Section 3: Data Sheet. A bidder shall be deemed to have the nationality of a country if the bidder is constituted, incorporated, or registered and operates in conformity with the provisions of the laws of that country.</p> <p>All bidders found to have a conflict of interest shall be disqualified. Bidders may be considered to have a conflict of interest if they are or have been associated in the past, with a firm or any of its affiliates that have been engaged by IOM to provide consulting services for the preparation of the design, specifications, and other documents to be used for the procurement of the goods, services or works required in the present procurement process.</p> <p>Bidders shall not be eligible to submit a bid if at the time of bid submission:</p> <ul style="list-style-type: none"> <li>● is included in the Ineligibility List, hosted by <a href="http://ungm.org">UNGM</a>, that aggregates information disclosed by Agencies, Funds or Programs of the UN System;</li> <li>● is included in the <a href="#">Consolidated United Nations Security Council Sanctions List</a>, including the <a href="#">UN Security Council Resolution 1267/1989 list</a>;</li> <li>● is included in the <a href="#">World Bank Corporate Procurement Listing of Non-Responsible Vendors</a> and <a href="#">World Bank Listing of Ineligible Firms and Individuals</a>;</li> <li>● Other sanctions lists, if applicable, as per the discretion of the IOM.</li> </ul>
<b>5. Eligible goods, works and services</b>	<p>All goods, works and/or services to be supplied under the contract shall have their origin in any country apart from the countries, if any, listed in Section 3: Data Sheet, and all expenditures made under the contract will be limited to such goods, works and services.</p> <p>For purposes of this clause, “origin” means the place where the goods are mined, grown, or produced or the place from which the related services are supplied. Goods are produced when, through manufacturing, processing, or substantial and major assembly of components, a commercially recognized product result that is substantially different in basic characteristics or in purpose or utility from its components.</p> <p>The origin of goods, works and services is distinct from the nationality of the bidder.</p>
<b>6. Proprietary information</b>	<p>The ITB documents and any specifications, plans, drawings, patterns, samples or information issued or furnished by IOM are issued solely for the purpose of enabling a bid to be completed</p>

	and may not be used for any other purpose. The ITB documents and any additional information provided to bidders shall remain the property of IOM. All documents which may form part of the bid will become the property of IOM, who will not be required to return them to your firm.
<b>7. Publicity</b>	During the ITB process, a bidder is not permitted to create any publicity in connection with the ITB.
SOLICITATION DOCUMENTS	
<b>8. Clarification of solicitation documents</b>	<p>Bidders may request clarifications on any of the ITB documents no later than the date indicated in Section 3: Data Sheet. Any request for clarification must be sent in writing in the manner indicated in Section 3: Data Sheet. Explanations or interpretations provided by personnel other than the named contact person will not be considered binding or official.</p> <p>IOM will provide the responses to clarifications through the method specified in Section 3: Data Sheet.</p> <p>IOM shall endeavor to provide responses to clarifications in an expeditious manner, but any delay in such response shall not cause an obligation on the part of IOM to extend the submission date of the bids, unless IOM deems that such an extension is justified and necessary.</p>
<b>9. Amendment of solicitation documents</b>	<p>At any time prior to the deadline of bid submission, IOM may for any reason, such as in response to a clarification requested by a bidder, modify the ITB in the form of an amendment to the ITB. Amendments will be made available to all prospective bidders.</p> <p>If the amendment is substantial, IOM may extend the deadline for submission of the bid to give the bidders reasonable time to incorporate the amendment into their bids.</p>
PREPARATION OF BIDS	
<b>10. Cost of preparation of bid</b>	The bidder shall bear all costs related to the preparation and/or submission of the bid, regardless of whether its bid is selected or not. IOM shall not be responsible or liable for those costs, regardless of the conduct or outcome of the procurement process.
<b>11. Language</b>	The bid, as well as any and all related correspondence exchanged by the bidder and IOM, shall be written in the language(s) specified in Section 3: Data Sheet.
<b>12. Documents comprising the bid</b>	<p>The bid shall comprise the following documents and related forms which details are provided in Section 3: Data Sheet:</p> <ul style="list-style-type: none"> <li>a) Documents establishing the eligibility and qualifications of the bidder.</li> <li>b) Technical bid</li> <li>c) Price Schedule</li> <li>d) Bid Security (if required)</li> </ul>
<b>13. Documents establishing eligibility and qualifications of the bidder</b>	The bidder shall furnish documentary evidence of its status as an eligible and qualified vendor, using the Forms provided in Section 7 and providing the documents required in those forms. In order to award a contract to a bidder, its qualifications must be documented to IOM's satisfaction.
<b>14. Technical bid</b>	The bidder is required to submit a technical bid using the form provided in Section 7 and taking into consideration the requirements in the ITB.
<b>15. Price Schedule</b>	<p>The Price Schedule shall be prepared using the form provided in Section 7 and taking into consideration the requirements in the ITB.</p> <p>The prices and discounts quoted by the bidder shall conform to the requirements specified below.</p>

	<ul style="list-style-type: none"> <li>● All items and lots (if applicable) must be listed and priced separately.</li> <li>● The price to be quoted shall be the total price of the bid, excluding any discounts offered.</li> <li>● The bidder shall quote any unconditional discounts and indicate the method for their application.</li> <li>● The INCOTERM shall be governed by the rules prescribed in the 2020 edition of INCOTERMS, published by The International Chamber of Commerce. The INCOTERM rules and place of destination are specified in Section 5: Schedule of Requirements.</li> <li>● Prices quoted by the bidder shall be fixed during the bidder’s performance of the contract and not subject to variation on any account unless otherwise specified in Section 3: Data Sheet. A bid submitted with an adjustable price shall be treated as non-compliant and shall be rejected. However, if in accordance with Section 3: Data Sheet, prices quoted by the bidder shall be subject to adjustment during the performance of the Contract, a bid submitted with a fixed price quotation shall not be rejected, but the price adjustment shall be treated as zero.</li> <li>● If indicated in Section 3: Data Sheet that bids are being invited for individual contracts (lots) and unless otherwise indicated in Section 3: Data Sheet, prices quoted shall correspond to 100 % of the items specified for each lot and to 100% of the quantities specified for each item of a lot. Bidders wishing to offer any price reduction (discount) for the award of more than one Lot shall specify the applicable price reduction.</li> </ul>
<p><b>16. Bid currencies</b></p>	<p>All prices shall be quoted in the currency or currencies indicated in Section 3: Data Sheet. Where bids are quoted in different currencies, for the purposes of comparison of all bids:</p> <ul style="list-style-type: none"> <li>● IOM will convert the currency quoted in the bid into the IOM preferred currency, in accordance with the prevailing IOM Operational Rate of Exchange on the date of the bid closure; and</li> <li>● In the event that IOM selects a bid for the award that is quoted in a currency different from the preferred currency in Section 3: Data Sheet, IOM shall reserve the right to award the contract in the currency of IOM’s preference, using the conversion method specified above.</li> </ul>
<p><b>17. Duties and taxes</b></p>	<p>The International Organization for Migration is exempt from all direct taxes, except charges for public utility services, and is exempt from customs restrictions, duties, and charges of a similar nature in respect of articles imported or exported for its official use. All quotations shall be submitted net of any direct taxes and any other taxes and duties, unless otherwise specified below:</p> <p>All prices shall:</p> <ul style="list-style-type: none"> <li>- be inclusive of VAT and other applicable indirect taxes</li> <li><input checked="" type="checkbox"/> be exclusive of VAT and other applicable indirect taxes</li> </ul>
<p><b>18. Bid validity period</b></p>	<p>Bids shall remain valid for the period specified in Section 3: Data Sheet, commencing on the deadline for submission of bids. A bid valid for a shorter period may be rejected by IOM and rendered non-responsive.</p> <p>During the bid validity period, the bidder shall maintain its original bid without any change, including the availability of the key personnel, the proposed rates and the total price.</p> <p>In exceptional circumstances, prior to the expiration of the bid validity period, IOM may request bidders to extend the period of validity of their bids. The request and the responses shall be made in writing and shall be considered integral to the bid.</p> <p>If the bidder agrees to extend the validity of its bid, it shall be done without any change to the</p>

	<p>original bid, but will be required to extend the validity of the bid security, if required, for the period of the extension, and in compliance with Article 19 (Bid Security) in all respects.</p> <p>The bidder has the right to refuse to extend the validity of its bid without forfeiting the bid security, if required, in which case, the bid shall not be further evaluated.</p>
<p><b>19. Bid Security</b></p>	<p>A bid security, if required by Section 3: Data Sheet, shall be provided in the amount and form indicated in the Section 3: Data Sheet. The bid security shall be valid for a minimum of thirty (30) days after the final date of validity of the bid.</p> <p>The bid security shall be included along with the bid. If a bid security is required by the ITB but is not found in the bid, the offer shall be rejected.</p> <p>If the bid security amount or its validity period is found to be less than is required by IOM, IOM shall reject the bid.</p> <p>In the event an electronic submission is allowed in Section 3: Data Sheet, bidders shall include a copy of the bid security in their bid and the original of the bid security must be sent via courier or hand delivery as per the instructions in Section 3: Data Sheet.</p> <p>Unsuccessful bidders' bid securities will be discharged/returned as promptly as possible but no later than thirty (30) days after the expiration of the period of bid validity prescribed by IOM pursuant to Article 18 (Bid Validity Period).</p> <p>The bid security may be forfeited by IOM, and the bid rejected, in the event of any, or combination, of the following conditions:</p> <ul style="list-style-type: none"> <li>● If the bidder withdraws its offer during the period of the bid validity specified in Section 3: Data Sheet, or;</li> <li>● In the event the successful bidder fails: <ul style="list-style-type: none"> <li>○ to sign the Contract after IOM has issued an award; or</li> <li>○ to furnish the Performance Security, insurances, or other documents that IOM may require as a condition precedent to the effectivity of the contract that may be awarded to the bidder.</li> </ul> </li> </ul>
<p><b>20. Joint Venture, Consortium or Association</b></p>	<p>If the bidder is a group of legal entities that will form or have formed a Joint Venture (JV), Consortium or Association for bid, each such legal entity will confirm in their joint bid that:</p> <ul style="list-style-type: none"> <li>● they have designated one party to act as a lead entity, duly vested with authority to legally bind the members of the JV, Consortium or Association jointly and severally, and this will be evidenced by a duly notarised Agreement among the legal entities, which will be submitted along with the bid; and</li> <li>● if they are awarded the contract, the contract shall be entered into by and between IOM and the designated lead entity, who will be acting for and on behalf of all the member entities comprising the joint venture.</li> </ul> <p>After the deadline for submission of bid, the lead entity identified to represent the JV, Consortium or Association shall not be altered without the prior written consent of IOM.</p> <p>If a JV, Consortium or Association's bid is the bid selected for award, IOM will award the contract to the joint venture, in the name of its designated lead entity. The lead entity will sign the contract for and on behalf of all other member entities.</p> <p>The lead entity and the member entities of the JV, Consortium or Association shall abide by the provisions of Article 21 (Only one Bid) herein in respect of submitting only one bid.</p> <p>The description of the organization of the JV, Consortium or Association must clearly define the expected role of each of the entities in the joint venture in delivering the requirements of</p>

	<p>the ITB, both in the bid and the JV, Consortium or Association Agreement. All entities that comprise the JV, Consortium or Association shall be subject to the eligibility and qualification assessment by IOM.</p> <p>A JV, Consortium or Association in presenting its track record and experience should clearly differentiate between:</p> <ul style="list-style-type: none"> <li>• Those that were undertaken together by the JV, Consortium or Association; and</li> <li>• Those that were undertaken by the individual entities of the JV, Consortium or Association.</li> </ul> <p>Previous contracts completed by individual experts working privately but who are permanently or were temporarily associated with any of the member firms cannot be claimed as the experience of the JV, Consortium or Association or those of its members, but should only be claimed by the individual experts themselves in their presentation of their individual credentials.</p> <p>JV, Consortium or Associations are encouraged for high value, multi-sectoral requirements when the spectrum of expertise and resources required may not be available within one firm.</p>
<p><b>21. Only one bid</b></p>	<p>The bidder (including the individual members of any Joint Venture) shall submit only one bid, either in its own name or as part of a Joint Venture.</p> <p>Bids submitted by two (2) or more bidders shall all be rejected if they are found to have any of the following:</p> <ul style="list-style-type: none"> <li>• they have at least one controlling partner, director or shareholder in common; or</li> <li>• any one of them receive or have received any direct or indirect subsidy from the other/s; or</li> <li>• they have the same legal representative for purposes of this ITB; or</li> <li>• they have a relationship with each other, directly or through common third parties, that puts them in a position to have access to information about, or influence on the bid of another bidder regarding this ITB process;</li> <li>• they are subcontractors to each other's bid, or a subcontractor to one bid also submits another bid under its name as lead bidder; or some key personnel proposed to be in the team of one bidder participates in more than one bid received for this ITB process. This condition relating to the personnel, does not apply to subcontractors being included in more than one bid.</li> </ul>
<p><b>22. Alternative bids</b></p>	<p>Unless otherwise specified in Section 3: Data Sheet, alternative bids shall not be considered. If submission of an alternative bid is allowed in Section 3: Data Sheet, a bidder may submit an alternative bid, but only if it also submits a bid conforming to the ITB requirements. Where the conditions for its acceptance are met, or justifications are clearly established, IOM reserves the right to award a contract based on an alternative bid.</p> <p>If multiple/alternative bids are being submitted, they must be clearly marked as "Main Bid" and "Alternative Bid". If no indication is provided as to which bid is the main bid and which is/are the alternative bid(s), then all bids will be rejected.</p>
<p><b>23. Pre-bid conference</b></p>	<p>When appropriate, a pre-bid conference will be conducted at the date, time and location and according to any instructions specified in Section 3: Data Sheet.</p> <p>If it is stated in Section 3: Data Sheet that the pre-bid conference is mandatory, a bidder which does not attend the pre-bid conference shall become ineligible to submit a bid under this ITB.</p>

	<p>If it is stated in Section 3: Data Sheet that the pre-bid conference is not mandatory, non-attendance shall not result in disqualification of an interested bidder.</p> <p>IOM will not issue any formal answers to questions from bidders regarding the ITB or bid process during the pre-bid conference. All questions shall be submitted in accordance with Article 41 (Clarification of Bids).</p> <p>The pre-bid conference shall be conducted for the purpose of providing background information only. Without limiting Article 26 (Bidders Responsibility) bidders shall not rely upon any information, statement or representation made at the pre-bid conference unless that information, statement or representation is confirmed by IOM in writing.</p> <p>Minutes of the pre-bid conference will be disseminated as specified in Section 3: Data Sheet. No verbal statement made during the conference shall modify the terms and conditions of the ITB, unless specifically incorporated in the minutes of the bidder's conference or issued/posted as an amendment to ITB.</p>
<p><b>24. Site inspection</b></p>	<p>When appropriate, a site inspection will be conducted at the date, time and location and according to any instructions specified in Section 3: Data Sheet.</p> <p>If it is stated in Section 3: Data Sheet that the site inspection is mandatory, a bidder who does not attend the site inspection shall become ineligible to submit a bid under this ITB.</p> <p>If it is stated in Section 3: Data Sheet that the site inspection is not mandatory, non-attendance, shall not result in disqualification of an interested bidder.</p> <p>Bidders participating in a site inspection shall be responsible for making and obtaining any visa arrangements that may be required for the bidders to participate in a site inspection.</p> <p>Prior to attending a site inspection, bidders shall execute an indemnity and a waiver releasing IOM in respect of any liability that may arise from:</p> <ul style="list-style-type: none"> <li>(i) loss of or damage to any real or personal property;</li> <li>(ii) personal injury, disease or illness to, or death of, any person;</li> <li>(iii) financial loss or expense, arising out of the carrying out of that site inspection; and</li> <li>(iv) transportation by IOM to the site (if provided) as a result of any accidents or malicious acts by third parties.</li> </ul> <p>IOM will not issue any formal answers to questions from bidders regarding the ITB or bid process during a site inspection. All questions shall be submitted in accordance with Article 8 (Clarification of solicitation documents).</p> <p>A site inspection will be conducted for the purpose of providing background information only. Without limiting Article 26 (Bidders Responsibility), bidders shall not rely upon any information, statement or representation made at a site inspection unless that information, statement or representation is confirmed by IOM in writing.</p>
<p><b>25. Errors or omissions</b></p>	<p>Bidders shall immediately notify IOM in writing of any ambiguities, errors, omissions, discrepancies, inconsistencies or other faults in any part of the ITB, with full details of those ambiguities, errors, omissions, discrepancies, inconsistencies or other faults.</p> <p>Bidders shall not benefit from such ambiguities, errors, omissions, discrepancies, inconsistencies or other faults.</p>
<p><b>26. Bidders responsibility to inform themselves</b></p>	<p>Bidders shall be responsible for informing themselves in preparing their bid. In this regard, bidders shall ensure that they:</p>



	<ul style="list-style-type: none"> <li>● examine and fully inform themselves in relation to all aspects of the ITB, including the Contract and all other documents included or referred to in this ITB;</li> <li>● review the ITB to ensure that they have a complete copy of all documents;</li> <li>● obtain and examine all other information relevant to the project and the scope of the requirements available on reasonable inquiry;</li> <li>● verify all relevant representations, statements and information, including those contained or referred to in the ITB or made orally during any clarification meeting or site inspection or any discussion with IOM, its employees or agents;</li> <li>● attend any Pre-bid conference or site inspection if it is mandatory under this ITB;</li> <li>● fully inform and satisfy themselves as to requirements of any relevant authorities and laws that apply, or may in the future apply, to the supply of the goods, works and/or services; and</li> <li>● form their own assessment of the nature and extent of the goods, works and /or services required as included in Section 5: Schedule of Requirements and properly account for all requirements in their bid.</li> </ul> <p>Bidders acknowledge that IOM, its directors, employees and agents make no representations or warranties (express or implied) as to the accuracy, currency or completeness of this ITB or any other information provided to the bidders.</p>
<p><b>27. No material change(s) in circumstances</b></p>	<p>The bidder shall inform IOM of any change(s) of circumstances arising during the ITB process, including but not limited to:</p> <ul style="list-style-type: none"> <li>● a change affecting any declaration, accreditation, license or approval;</li> <li>● major re-organizational changes, company re-structuring, a take-over, buy-out or similar event(s) affecting the operation and/or financing of the bidder or its major sub-contractors;</li> <li>● a change to any information on which IOM may rely on assessing bids.</li> </ul>
<p>SUBMISSION AND OPENING OF BIDS</p>	
<p><b>28. Instruction for bid submission</b></p>	<p>The bidder shall submit a duly signed and complete bid comprising the documents and forms in accordance with requirements in Section 3: Data Sheet. The Price Schedule shall be submitted together with the Technical Bid. The bid shall be delivered according to the method specified in Section 3: Data Sheet.</p> <p>The bid shall be signed by the bidder or person(s) duly authorized to commit the bidder. The authorization shall be communicated through a document evidencing such authorization issued by the legal representative of the bidding entity, or, if requested, a Power of Attorney, accompanying the bid.</p> <p>Bidders must be aware that the mere act of submission of a bid, in and of itself, implies that the bidder fully accepts the IOM General Conditions of Contract.</p>
<p><b>29. Deadline for bid submission</b></p>	<p>Complete bids must be received by IOM in the manner, and no later than the date and time, specified in Section 3: Data Sheet. If any doubt exists as to the time zone in which the Bid should be submitted, refer to <a href="http://www.timeanddate.com/worldclock/">http://www.timeanddate.com/worldclock/</a>. It shall be the sole responsibility of the bidders to ensure that their bid is received by the closing date and time. IOM shall accept no responsibility for bids that arrive late due to the courier company or any technical issues and shall only recognize the actual date and time that the bid was received by IOM.</p>

	<p>IOM may, at its discretion, extend this deadline for the submission of bids by amending the solicitation documents in accordance with Article 9 Amendment of solicitation documents. In this case, all rights and obligations of IOM and bidders subject to the previous deadline will thereafter be subject to the new deadline as extended.</p>
<p><b>30. Withdrawal, substitution and modification of bids</b></p>	<p>A bidder may withdraw, substitute, or modify its bid after it has been submitted at any time prior to the deadline for submission by sending a written notice to IOM, duly signed by an authorized representative and shall include a copy of the authorization (or a Power of Attorney). The corresponding substitution or modification of the bid, if any, must accompany the respective written notice. All notices must be submitted in the same manner as specified for submission of bids, by clearly marking them as “WITHDRAWAL”, “SUBSTITUTION” OR “MODIFICATION”.</p> <p>However, after the deadline for bid submission, the bids shall remain valid and open for acceptance by IOM for the entire bid validity period, as may be extended.</p> <p>Bids requested to be withdrawn prior to the deadline for submission of the bids shall be made available for collection by the bidder that submitted it within 15 days of its withdrawal. Otherwise, IOM shall have the right to discard such bid unopened without further notice to the bidder. IOM shall not be responsible to return the bid to the bidder at IOM’s cost.</p>
<p><b>31. Storage of bids</b></p>	<p>Bids received prior to the deadline of submission and the time of opening shall be securely kept unopened until the specified bid opening date stated in Section 3: Data Sheet. No responsibility shall be attached to IOM for prematurely opening an improperly addressed and/or identified bid.</p>
<p><b>32. Bid opening</b></p>	<p>Bids will be opened by a committee formed by IOM consisting of at least two (2) personnel.</p> <p>Bidders may attend the opening of the bids if stated in Section 3: Data Sheet.</p> <p>The bidders’ names, modifications, withdrawals, bid prices, the condition of the envelope labels/seals, the number of folders/files and all other such details as IOM may consider appropriate will be announced at the opening and recorded on the bid opening report, which will be available for viewing only to bidders who have submitted a bid for a period of thirty days from the date of opening. Information not included in the bid opening report will not be provided to bidders. No bid shall be rejected at the opening stage, except for late submissions.</p>
<p><b>33. Late bids</b></p>	<p>Any bid received by IOM after the deadline for submission of bids will be destroyed unless the bidder requests that it be returned and assumes the responsibility and expenses for the re-possession of the returned bidding documents.</p> <p>In exceptional circumstances, late bids may be accepted if it is determined that the submission was sent in ample time prior to the bid closing and the delay could not be reasonably foreseen by the bidder or was due to force majeure.</p>
<p>EVALUATION OF BIDS</p>	
<p><b>34. Confidentiality</b></p>	<p>Information relating to the examination, evaluation, and comparison of bids, and the recommendation of contract award, shall not be disclosed to bidders or any other persons not officially concerned with such process, even after publication of the contract award.</p> <p>Any effort by a bidder or anyone on behalf of the bidder to influence IOM in the examination, evaluation and comparison of the bids or contract award decisions may, at IOM’s decision, result in the rejection of its bid and may subsequently be subject to the application of prevailing IOM’s vendor sanctions procedures.</p>
<p><b>35. Evaluation of bids</b></p>	<p>IOM shall evaluate a bid using only the methodologies and criteria defined in this ITB. No other criteria or methodology shall be permitted.</p> <p>IOM shall conduct the evaluation solely based on the bids received according to the evaluation</p>

	<p>criteria in Section 4.</p> <p>Evaluation of bids shall be undertaken in the following steps:</p> <ol style="list-style-type: none"> <li>a) Preliminary examination</li> <li>b) Evaluation of eligibility and qualification</li> <li>c) Evaluation of technical bids</li> <li>d) Evaluation of prices of bids found to be substantially compliant.</li> </ol> <p>After completion of the evaluation, but prior to award, IOM shall conduct a post-qualification assessment of the bidder recommended for the award (if pre-qualification was not done) as per Article 40 (Post-qualification).</p>
<b>36. Preliminary examination</b>	IOM shall examine the bids to determine whether they are complete with respect to minimum documentary requirements, whether the documents have been properly signed, and whether the bids are generally in order, among other indicators that may be used at this stage. IOM reserves the right to reject any bid at this stage.
<b>37. Evaluation of eligibility and qualification</b>	The eligibility and Qualification of the bidder will be evaluated against the Minimum Eligibility/Qualification requirements specified in Section 4: Evaluation Criteria and in Article 4 (Eligible Bidders).
<b>38. Evaluation of technical bids</b>	Technical evaluation will be conducted to establish substantial compliance, as per the criteria included in Section 4: Evaluation Criteria. When the bid varies in one or more aspect/s from the minimum technical specifications and/or delivery requirements specified in Section 5: Schedule of Requirements, the bid will not be considered substantially compliant and will not be evaluated further.
<b>39. Evaluation of prices</b>	The prices of bids found to be substantially compliant will be compared to identify the most substantially compliant bid which represents the lowest overall costs to IOM.
<b>40. Post-qualification</b>	<p>IOM reserves the right to undertake a post-qualification assessment, aimed at determining, to its satisfaction, the validity of the information provided by the bidder. Such exercise shall be fully documented and may include, but need not be limited to, all or any combination of the following:</p> <ol style="list-style-type: none"> <li>a) Verification of accuracy, correctness and authenticity of the information provided by the bidder;</li> <li>b) Validation of the extent of compliance to the ITB requirements and evaluation criteria based on what has so far been found by the evaluation team;</li> <li>c) Inquiry and reference checking with Government entities with jurisdiction over the bidder, or with previous clients, or any other entity that may have done business with the bidder;</li> <li>d) Inquiry and reference checking with previous clients on the performance on ongoing or completed contracts, including physical inspections of previous works, as deemed necessary;</li> <li>e) Physical inspection of the bidder's offices, branches or other places where business transpires, with or without notice to the bidder;</li> <li>f) Other means that IOM may deem appropriate, at any stage within the selection process, prior to awarding the contract.</li> </ol>
<b>41. Clarification of bids</b>	IOM may request clarification or further information in writing from the bidders at any time during the evaluation process. The bidders' responses shall not contain any changes regarding

	<p>the substance or price of the bid, except to confirm the correction of arithmetic errors discovered by IOM in the evaluation of the bids, in accordance with Instructions to Bidders Article 25 (Errors or omissions).</p> <p>IOM may use such information in interpreting and evaluating the relevant bid but is under no obligation to take it into account.</p>
<p><b>42. Responsiveness of bid</b></p>	<p>IOM's determination of a bid's responsiveness is to be based on the contents of the bid itself. A substantially responsive bid is one that conforms to all the terms, conditions, and specifications of the bidding documents without material deviation, reservation, or omission. A material deviation, reservation, or omission is one that:</p> <ul style="list-style-type: none"> <li>a) affects in any substantial way the scope, quality, or performance of the goods, services and/or works specified in the contract; or</li> <li>b) limits in any substantial way, inconsistent with the bidding documents, IOM's rights or the bidder's obligations under the contract; or</li> <li>c) if rectified would unfairly affect the competitive position of other bidders presenting substantially responsive bids.</li> </ul> <p>If a bid is not substantially responsive, it shall be rejected by IOM and may not subsequently be made responsive by the bidder by correction of the material deviation, reservation, or omission.</p>
<p><b>43. Nonconformities, reparable errors and omission</b></p>	<p>Provided that a bid is substantially responsive, IOM may waive any non-conformities or omissions in the bid that, in the opinion of IOM, do not constitute a material deviation. These are a matter of form and not of substance and can be corrected or waived without being prejudicial to other bidders.</p> <p>Provided that a bid is substantially responsive IOM may request the bidder to submit the necessary information or documentation, within a reasonable period, to rectify nonmaterial nonconformities or omissions in the bid related to documentation requirements. Such omission shall not be related to any aspect of the price of the bid. Failure of the bidder to comply with the request may result in the rejection of its bid.</p> <p>For bids that have passed the preliminary examination, IOM shall check and correct arithmetical errors as follows:</p> <ul style="list-style-type: none"> <li>a) if there is a discrepancy between the unit price and the line-item total that is obtained by multiplying the unit price by the quantity, the unit price shall prevail and the line item total shall be corrected, unless in the opinion of IOM there is an obvious misplacement of the decimal point in the unit price; in which case, the line-item total as quoted shall govern and the unit price shall be corrected;</li> <li>b) if there is an error in a total corresponding to the addition or subtraction of subtotals, the subtotals shall prevail, and the total shall be corrected; and</li> <li>c) if there is a discrepancy between words and figures, the amount in words shall prevail, unless the amount expressed in words is related to an arithmetic error, in which case the amount in figures shall prevail.</li> </ul> <p>If the bidder that submitted the lowest evaluated bid does not accept the correction of errors, its bid shall be rejected, and its bid security may be forfeited.</p>
<p><b>44. Right to accept any bid and to reject any or all bids</b></p>	<p>IOM reserves the right to accept or reject any bid, and to annul the bidding process and reject all bids at any time prior to contract award, without thereby incurring any liability to the affected bidder or bidders or any obligation to inform the affected bidder or bidders of the grounds for IOM's action. IOM shall not be obliged to award the contract to the lowest priced offer.</p>

<b>45. Samples</b>	<p>Where required as per Section 5: Schedule of Requirements, free, non-returnable samples shall be provided by the bid submission deadline for evaluation and testing by IOM or their representative, of the item and/or the packing and packaging, prior to any award. Samples will be subject to technical review and laboratory analysis where appropriate. Samples provided to IOM are non-returnable unless otherwise stated. Samples should be marked with the ITB number.</p> <p>If a bidder fails to provide samples or documents requested by IOM in a timely manner, IOM may declare the bid unsuccessful.</p>
<b>AWARD OF CONTRACT</b>	
<b>46. Award criteria</b>	<p>In the event of a Contract award, IOM shall award the contract to a bidder who has been determined as eligible and qualified and whose bid has been determined to be the lowest-priced, substantially compliant offer to the ITB. IOM reserves the right to conduct negotiations with the bidder recommended for the award on the content of their bid.</p>
<b>47. Right to vary requirement at time of award</b>	<p>At the time the Contract is awarded, IOM reserves the right to increase or decrease the quantity of goods, works and/or services originally specified in Section 5: Schedule of Requirements, provided this does not exceed the percentages specified in Section 3 Data Sheet, and without any change in the unit prices or other terms and conditions of the bid and the bidding document.</p>
<b>48. Notification of award</b>	<p>Prior to the expiration of the period of bid validity, IOM will notify the successful bidder in writing by email, fax or post, that its bid has been accepted. Please note that the bidder, if not already registered at the appropriate level in UNGM, will be required to complete the vendor registration process on the UNGM prior to the signature and finalization of the contract.</p>
<b>49. Debriefing</b>	<p>In the event that a bidder is unsuccessful, the bidder may request a debriefing from IOM. The purpose of the debriefing is to discuss the strengths and weaknesses of the bidder's submission, in order to assist the bidder in improving its future bids for IOM procurement opportunities. The content of other bids and how they compare to the bidder's submission shall not be discussed.</p>
<b>50. Performance security</b>	<p>The successful bidder, if so specified in Section 3: Data Sheet shall furnish performance security in the amount and form specified therein, within the specified number of days after receipt of the contract from IOM. Banks issuing performance securities must be acceptable to the IOM controller, i.e. banks certified by the central bank of the country to operate as a commercial bank. IOM shall promptly discharge the bid securities of the unsuccessful bidders pursuant to Article 19 (Bid Security).</p> <p>Failure of the successful bidder to submit the above-mentioned performance security or sign the contract shall constitute sufficient grounds for the annulment of the award and forfeiture of the bid security. In that event IOM may award the contract to the next lowest evaluated bidder, whose offer is substantially responsive and is determined by IOM to be qualified to perform the contract satisfactorily.</p>
<b>51. Bank guarantee for advance payment</b>	<p>Except when the interests of IOM so require, it is IOM's standard practice not to make advance payment(s) (i.e., payments without having received any outputs). If an advance payment is allowed as per Section 3: Data Sheet, and if specified there, the bidder shall submit a Bank Guarantee in the full amount of the advance payment. Banks issuing bank guarantees must be acceptable to the IOM controller, i.e., banks certified by the central bank of the country to operate as a commercial bank.</p>
<b>52. Liquidated Damages</b>	<p>If specified in Section 3: Data Sheet, IOM shall apply Liquidated Damages for the damages and/or risks caused to IOM resulting from the Contractor's delays or breach of its obligations as per the Contract.</p>

<b>53. Proposal protest</b>	Any proposer that believes to have been unjustly treated in connection with this proposal process or any contract that may be awarded as a result of such proposal process may submit a complaint to <a href="mailto:m SCU@iom.int">m SCU@iom.int</a> .
-----------------------------	---

**SECTION 3: DATA SHEET**

The following specific data shall complement, supplement, or amend the Provisions in Section 2: Instructions to Bidders. In case there is a conflict, the provisions herein shall prevail over those in Section 2: Instructions to Bidders.

Ref. Article in Section 2		Specific Instructions / Requirements
1.	Scope	The reference number of this Invitation to Bid (ITB) FJ2024/FJ2024/RFP01/001, construction of a Multipurpose Evacuation Centre at Rokovoka, Nalawa Ra Fiji, including supply and delivery of construction materials as further described in Section 5 of this ITB.
2.	Eligible bidders	Bidders from Fiji are eligible to Bid.
3.	Eligible goods, works and services	Goods, works and/or services with origin in Fiji are eligible in this bidding process.
4.	Clarification of solicitation documents	Contact details for clarification of solicitation documents: Focal Person: Shevneel Kumar Address: FNPF Place level 5, Suva. E-mail address: shkumar@iom.int  <b>ATTENTION: BIDS SHALL NOT BE SUBMITTED TO THE ABOVE ADDRESS BUT TO THE ADDRESS FOR BID SUBMISSION AS SET OUT BELOW (see Data Sheet Article 28).</b>

		<p>Deadline for submitting requests for clarifications/questions: Date: 19-April-2024. Time: 5pm. Time zone: Suva, Fiji Time (GMT + 12).</p> <p>Manner of disseminating supplemental information to the ITB and responses/clarifications to queries: Direct communication to prospective Bidders by email and posting on the website. <a href="http://www.iom.int">www.iom.int</a></p>
5.	Language	All bids, information, documents, and correspondence exchanged between IOM and the bidders in relation to this bid process shall be in English.
6.	Price adjustment	The price quoted by the Bidder shall not be subject to adjustment during the performance of the contract.
7.	Partial bids (lots)	Partial bids shall not be allowed. Bidders must quote prices for the total requirement requested under Section 5. Schedule of Requirements. Evaluation will be done for the total requirement.
8.	Bid currencies	Prices shall be quoted in Fijian Dollars (FJD)
9.	Duties and taxes	All prices shall: Be exclusive of VAT and other applicable indirect taxes.
18.	Bid validity period	90 Days.
19.	Bid security	Not Required.
22.	Alternative bids	Not accepted.
23.	Pre-bid conference	Will not be conducted.

24.	Site inspection	<p>A site inspection will be held.</p> <p>Time and time zone: 10am Fiji Time (GMT + 12).</p> <p>Date: 18<sup>th</sup> April 2024</p> <p>Location: Rokovoka Village, Ra.</p> <p>The focal point for the arrangement is:</p> <p>Name: Shevneel Kumar</p> <p>Telephone: 9987401</p> <p>E-mail: <a href="mailto:shkumar@iom.int">shkumar@iom.int</a></p> <p>Bidders shall notify the focal point 3 days in advance as to whether they intend to participate in the site inspection and the details of their representatives who will attend.</p> <p>The site inspection is:</p> <p><input type="checkbox"/> mandatory</p> <p><input checked="" type="checkbox"/> <b>not mandatory</b></p>
28.	Instruction for bid submission	<p>Allowable manner of submitting proposals:</p> <p><input type="checkbox"/> e-tendering</p> <p><input checked="" type="checkbox"/> <b>Email</b></p> <p><input type="checkbox"/> Courier / hand delivery</p> <p><b>SUBMISSION BY EMAIL:</b></p> <p>Bid submission address: <a href="mailto:shkumar@iom.int">shkumar@iom.int</a> <b>PLEASE DO NOT SEND EMAILS WITH YOUR BID TO ANY OTHER EMAIL ADDRESS (NOT EVEN AS CC. or BCC).</b></p> <ul style="list-style-type: none"> <li>▪ File Format: PDF.</li> <li>▪ File names must be maximum 60 characters long and must not contain any letter or special character other than from Latin alphabet/keyboard.</li> <li>▪ All files must be free of viruses and not corrupted.</li> </ul>



		<ul style="list-style-type: none"> <li>▪ Max. File Size per transmission: 8 Mb.</li> </ul> <p>Mandatory subject of email: FJ2024/PRFQ01/001- Construct and Delivery of Rokovoka Evacuation Centre.</p> <ul style="list-style-type: none"> <li>▪ If the bid consists of large files, it is recommended that these files be sent in separate emails prior to the submission deadline.</li> <li>▪ Multiple emails must be clearly identified by indicating in the subject line “email no. X of Y”, and the final “email no. Y of Y”.</li> <li>▪ Documents which are required in original (e.g. bid security) should be sent to the below address with a PDF copy submitted as part of the electronic submission: n/a</li> <li>▪ It is recommended that the entire bid be consolidated into as few attachments as possible.</li> <li>▪ The bidder should receive an email acknowledging email receipt.</li> </ul>
29.	Deadline for bid submission	<p>Date: 26<sup>th</sup> April 2024</p> <p>Time: 5pm.</p> <p>Time zone: Fiji Time (GMT+)</p>
32.	Bid opening	<p><input checked="" type="checkbox"/> <b>Public bid opening will not be held.</b></p> <p><input type="checkbox"/> Public bid opening will be held as per the details below.</p> <p><input type="checkbox"/> Date and Time: Click or tap here to enter text.</p> <p>Venue: Click or tap here to enter text.</p>
	Expected date for commencement of contract	6 <sup>th</sup> May 2024.
47.	Right to vary requirement at time of award	<p>The maximum percentage by which quantities may be increased is n/a.%</p> <p>The maximum percentage by which quantities may be decreased is n/a.%</p>
	Contract award to one or more bidder	IOM will award a contract to: One Bidder only.

50.	Type of contract to be awarded	<b>LEG-C.5. CONSTRUCTION AGREEMENT</b>
50.	Conditions of contract to apply	Construction Agreement
52.	Performance security	Not Required.
53.	Advance payment	Not Allowed. If allowed Bank Guarantee- to be provided by each vendor.
54.	Liquidated Damages	Percentage of contract price per day of delay: 0.1.% up to a maximum of 10% of the Contract value, after which IOM may terminate the contract.
	Other information related to the ITB	<i>n/a</i>

**SECTION 4: EVALUATION CRITERIA**

**Preliminary Examination Criteria**

All criteria will be evaluated on a Pass/Fail basis and checked during Preliminary Examination.

<b>Criteria</b>	<b>Documents to establish compliance</b>
Completeness of the bid	All documents and technical documentation requested in Section 2: Instructions to Bidders Article 12 have been provided and are complete
Bidder accepts IOM General Conditions of Contract as specified in Section 6.	Form C: Bid Submission
Bid Validity	Form C; Bid Submission

**Eligibility and Qualification Criteria**

All criteria will be evaluated on a Pass/Fail basis.

If the bid is submitted as a Joint Venture, Consortium or Association, each member should meet the minimum criteria, unless otherwise specified.

Eligibility Criteria	Documents to establish compliance
Bidder is a legally registered entity	Form D: Bidder Information (for New Vendors)- Reg Certificate.
Bidder belongs to a diverse supplier group including micro, small or medium sized enterprise, women or youth owned business or other.	Form D: Bidder Information (for new vendors)
Vendor is not suspended, nor otherwise identified as ineligible by any UN Organization, the World Bank Group or any other International Organization in accordance with Section 2 Article 4.	Form C: Bid Submission
No conflicts of interest in accordance with Section 2 Article 4.	Form C: Bid Submission
The bidder has not declared bankruptcy, in not involved in bankruptcy or receivership proceedings, and there is no judgment or pending legal action against the vendor that could impair its operations in the foreseeable future	Form C: Bid Submission- relevant financial statements.
Certificates and Licences:	Form D: Bidder Information (for new vendors)

<ul style="list-style-type: none"> <li>● Duly authorized to act as Agent on behalf of the Manufacturer, or Power of Attorney, if bidder is not a manufacturer.</li> <li>● Official appointment as local representative, if bidder is submitting a bid on behalf of an entity located outside the country.</li> <li>● Patent Registration Certificates if any of technologies submitted in the bid is patented by the bidder.</li> <li>● Export/Import Licenses, if applicable.</li> </ul>	
---	--

Qualification Criteria	Documents to establish compliance
History of non-performing contracts: Non-performance of a contract did not occur as a result of contractor default within the last 3 years.	Form F: Eligibility and Qualification Form
Litigation History: No consistent history of court/arbitral award decisions against the bidder for the last 3 years.	Form F: Eligibility and Qualification Form
<b>Previous Experience:</b>	

Minimum 3 years of relevant experience.	Form F: Eligibility and Qualification Form
A minimum of 3 contracts of similar value, nature and complexity have been implemented over the last 3 years. <i>(For JV/Consortium/Association, all Parties cumulatively should meet requirement).</i>	Form F: Eligibility and Qualification Form
<b>Financial Standing:</b>	
Liquidity: the ratio Average current assets / Current liabilities over the last 3 years must be equal or greater than 1.	Copy of audited financial statements for the last three years. / Form F: Eligibility and Qualification Form
Turnover: Bidders should have an annual sales turnover of minimum last three years. <i>(For JV/Consortium/Association, all Parties cumulatively should meet requirement).</i>	Copy of audited financial statements for the last three years. Form F: Eligibility and Qualification Form

#### Technical Evaluation Criteria

Criteria	Documents to establish compliance
Goods/works/services offered in the bid are substantially compliant and do not contain any material deviation(s) from the minimum required as included in Section 5: Schedule of Requirements.	Section 5: Schedule of Requirements and Form G: Technical Bid
The bid is substantially compliant with the minimum Delivery Requirements included in Section 5: Schedule of Requirements and do not contain any material deviation(s).	Section 5: Schedule of Requirements and Form G: Technical Bid.

#### Evaluation of Prices

Criteria	Documents to establish compliance
Price comparison shall be based on the landed price, including transportation, insurance, and the total cost of ownership (including spare parts, consumption, installation, commissioning, training, special packaging, etc., where applicable).	Form H: Price Schedule

## **SECTION 5: SCHEDULE OF REQUIREMENTS**

Evacuation Centre Work: Rokovuaka

TERMS OF REFERENCE: **Construction of a Multipurpose Evacuation Centre, April 2024**

### 1. Background and Objectives

#### **1.2 Context**

Fiji is vulnerable to floods and tropical cyclones (TCs). These hazards have already caused serious disruptions to the country including human, material, economic and environmental losses. In 2016, Tropical Cyclone Winston displaced 62,000 people, or 6% of Fiji's total population. IOM recognizes that environmental hazard results in a disaster when the event exceeds the ability of the affected community or society to cope using its own resources. Acknowledging these challenges, IOM is working in partnership with the Government of Fiji through the National Disaster Management Office (NDMO) and Save the Children Fiji to prioritise building Fijian communities' resilience to minimise the impact of hazards. Through this focus on resilience, IOM aims to strengthen, support, and build on the preparedness and capacity of communities and families to break recurrent cycles of displacement. One critical aspect of this aim is the pursuit of resilient, safe, and secure evacuation centres in communities vulnerable to hazards. IOM is seeking vendors to support the rehabilitation and retrofitting of community structures to enhance their utility as evacuation centres and ensure the compliance to humanitarian standards.

#### **1.3 Assignment Objective and Conditions**

##### OVERALL OBJECTIVE

For this Request for Quotation (RFQ), IOM is seeking a suitably qualified and experienced contractor to construct an Evacuation Centre at a selected lot in Rokovuaka Village in Ra Province, Western based on the certified drawings of the evacuation centres included in Annex A. This Evacuation Centre is 28.55m by 17.3m and will provide safe refuge for up to 150 evacuees in times of crisis. It is anticipated that all works will be completed within four (4) months of starting construction. The Contractor will be expected to budget and account for delays due to weather, fluctuations in material costs, etc.

During construction, the Contractor will be expected to maintain accurate and up-to-date as-built records of the works, including but not limited to sizes, locations and depths of footings, service pipes and ducts, including junctions, changes in direction, fittings, access points and sumps.

The Contractor will deliver the Works in accordance with the certified drawings. Any departures from the certified drawings must be reviewed and approved by IOM prior to undertaking the Works. As-built drawings which include any departures from the certified drawings, must be pre-approved by IOM. Before final acceptance of any completed works, the Contractor shall mark-up drawings with the as-built information and submit to IOM the marked up as-built drawings, in good condition.

The Contractor will engage and pay for a suitably qualified and licensed land surveyor to set out the Works, including fences and site works, and shall maintain site boundary pegs and temporary

benchmarks in good condition and correct positions until the set-out is certified correct. Any peg or benchmark accidentally or purposely removed before this time shall be re-established by the original surveyor at the Contractor's cost.

## CONSTRUCTION SCHEDULE OF WORKS

Within the timeframe specified in this Terms of Reference (TOR) and no later than the date of signature of the Contract the Contractor shall submit a construction Schedule of Works showing the following:

- Sequence of Work (all estimated dates on which the Contractor shall start and finish each portion of the Work)
- Critical paths of activities (i.e. procurement activities and material lead times, construction activities, critical milestones, and scheduled hold points for approvals)
- Allowance for holidays.
- Activity inter-relationships.
- External dependencies including permit approvals and work by others.
- Estimate resources, labour and equipment.
- Inspections and testing (materials and workmanship on-site)
- Submittals and prototypes (shop drawings and materials samples)
- Periods within which various stages or parts of the work are to be executed.

Revisions: Revise the construction program as required by the progress of the work. Submit revisions with each Monthly Progress Claim. Identify changes since the previous version and show the estimated percentage of completion for each item of work. Display an on-site up-to-date construction schedule of works.

## SITE MEETINGS

Attend site meetings with the IOM Project Engineer to review progress, co-ordination and other matters as requested by IOM. Site meetings shall be held at a regular time and place each fortnight, or at regular intervals determined by the IOM Project Engineer. Arrange the attendance of relevant site personnel, and other parties, if directed.

## SITE PERSONNEL AND RECORDS

Site personnel: Retain a full-time, experienced Site / Construction Manager on site for the duration of the Works. The Site / Construction Manager shall be authorised to receive directions from the IOM Project Engineer.

Records: The Site / Construction Manager must maintain a daily site diary which shall record general progress and any significant events, the number of personnel and list of onsite subcontractors, temperature and weather conditions, meetings, visits and inspections, delays, unusual events and accidents. The original site diary shall be available for inspection and copying by the IOM Project Engineer at any time without notice.

### **TEMPORARY HOARDINGS AND SAFETY FENCES**

It will remain the Contractors responsibility to prepare applications and obtain all relevant authority permits required for hoardings and safety fences and to maintain such safety hoardings to the satisfaction of the relevant authority for the duration of the Project.

Enclose the Works with suitable temporary barriers and protection, prevent the entry of unauthorised persons onto the site, and prevent injury, damage, vandalism and theft. Supervise openings and access points to the Works during working hours and secure the Works during nonworking hours.

### **OCCUPATIONAL HEALTH AND SAFETY**

Take responsibility and ensure the health and safety of all employees. Be aware of and comply with the statutory occupational health and safety obligations and relevant acts and ordinances. Notify the IOM Project Engineer stating total hours worked, number of accidents and time lost, rehabilitation reports and other relevant information. Remove from site of any person not wearing or using required safety clothing and equipment, or any person who refuses to carry out occupational health and safety related instructions.

## 2. Scope of Work

### 2.1 Location

Address:

Rokovuaka, Ra

The site is right next to the King's Highway within Rokovuaka Village.

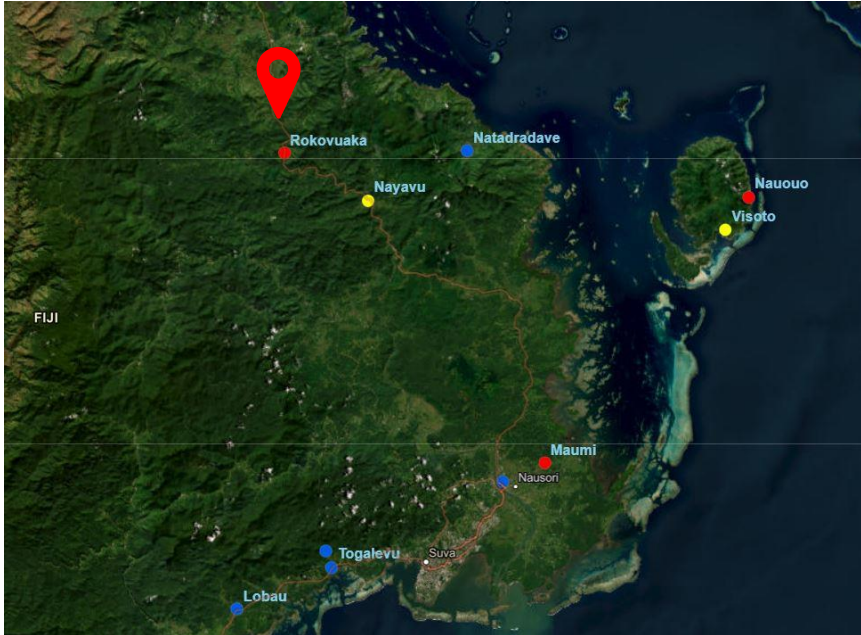

Coordinates	
Latitude	Longitude
178.4866525	-17.6355756

### Sample Photos





## 2.2 Requested Construction and Rehabilitation Designs

### Certified Designs:

Please see Annex A.

## 3. Submission Requirements and Evaluation

### 3.1 Submission Requirements

Submit the following as part of your quotation:

- A description of your company, including profile, portfolio, qualification, capacity, and expertise that is relevant to the Terms of Reference.
- A methodology, approach and implementation plan that demonstrates an understanding of the project requirements.
- A Costed BOQ (Annex B) in line with the certified designs (Annex A)
- Proposed Schedule of Works (Program)
- Provide information relevant to the evaluation criteria, including but not limited to:
  - o Key Personnel (Annex C)
  - o Governance / Organizational Structure
  - o List of Partnerships
  - o List of similar equivalent projects
  - o List of sub-contractors
  - o List of equipment (Annex D)
  - o List of current workload / ongoing projects
- Submission of certified revisions to the Certified Designs of the Evacuation Centre (applicable only if the Contractor is proposing an alternative design for the value management / innovation).
- Record of previously completed construction projects of a similar nature.
- References for three previous clients (projects of similar scale and complexity) for verification of past projects.
- Insurance Certificates
- An Occupational, Health and Safety Policy and/or Quality Assurance and Safety Standards Documentation
- A Construction Environment Management Plan for the Works
- Certificate of Building Company Registration
- Demonstrated Working Capital of at least 50% of Project Value
- Performance Bond (10%) of Cost Proposal

Please submit your quotations to Shevneel Kumar, [shkumar@iom.int](mailto:shkumar@iom.int). Also reachable at 9987401 for any questions.

### 3.2 Evaluation Criteria

Multi-Purpose Evacuation Centre Construction in Fiji Bid Document Evaluation		
<b>Proposal Evaluation Criteria</b>		
<b>Mandatory Criteria (non-weighted)</b>		<b>Evaluation Method</b>
Duly completed all RFQ template schedules		Yes/No
Demonstrated working capital of no less than 50% of the estimated project cost		Yes/No
Certificate of Registration - suitably qualified Building Contractor (Fiji)		Yes/No
Quality and Safety Standards Documentation (ISO 9001)		Yes/No
Duly completed IOM Vendor Information Sheet Form		Yes/No
Contractor is currently not on list of 'blacklisted contractors'		Yes/No
Insurances (public liability, professional indemnity, workcover)		Yes/No
<b>Weighted Evaluation Criteria</b>		<b>Evaluation Method</b>
<b>Criteria 1: Company Profile and Resources (25%)</b>		<b>Score out of 10</b>
This evaluation criteria takes into consideration Key Personnel, Governance, Sub-Contractors, and Equipment		
	Key Personnel	Name, position and CV of nominated key personnel and full time equivalent (FTE) allocation on this
	Governance	Provide information about the company structure and the organisational chart for nominated key personnel
	List of Partnerships	Provide information about previous and/or current partnerships
	List of similar equivalent projects (location, technicality, value)	Provide information about previous and/or current projects. Company portfolio must include project name, location, contract value, start and finish date
	List of Sub-Contractors	Company name, previous experience and nominated key personnel
	List of Equipment (owned by company)	All equipment to be supported by specifications, warranties and testing data where available
	List of Equipment (to be rented by company)	All equipment to be supported by specifications, warranties and testing data where available
<b>Criteria 2: Methodology and Schedule (25%)</b>		<b>Score out of 10</b>
This evaluation criteria takes into consideration Key Personnel, Governance, Sub-Contractors, and Equipment		
	Demonstrates an understanding of the project requirements	Methodology submitted takes into consideration scope of works, staging requirements, specific site constraints, mobilisation of labour and materials, logistics, access, etc.
	Program	Gantt chart submitted in accordance with the nominated duration for works
<b>Criteria 3: Capability and Past Performance (10%)</b>		<b>Score out of 10</b>
	Current Workload	Provide a list of projects currently in delivery and confirmation that company is adequately resourced to undertake additional works
	References	Provide three references from past clients / projects of similar scale and complexity
	Value-Management	(ie. if the Contractor puts forward a cost-saving methodology or material that still delivers on the
	Local Labour	(ie. if the Contractor commits to engaging a % of the local population to stimulate local economy)
	Innovation	(ie. if the Contractor provides an alternative design that will improve the integrity / robustness of the
<b>Price (40%)</b>		<b>Evaluation Method (formula)</b>
	$p = y * \mu / z$	$p$ = points for the financial proposal being evaluated, $y$ = maximum number of points for the financial proposal, $\mu$ = price of the lowest priced proposal, $z$ = price of the proposal being evaluated
<b>Risk Based Evaluation</b>		<b>Evaluation Method (qualitative / commentary)</b>
<b>Financial</b>		
Realistic Cost Proposal Yes/No		
Adherence to IOM Payment Terms Yes/No		
Review audited statements from previous 3 years and determine risks / benefits - acceptable or not acceptable		
<b>Legal</b>		
Review any departures to the Contract and determine risks / benefits - acceptable or not acceptable		
Value-for Money is to be evaluated after taking into account all of the weighted evaluation criteria, price and risk.		

### 3.3 Accompanying Annexes

This TOR has the following annexes as supporting documents to this Request for Proposal:

## Annex A: Certified Evacuation Centre Designs

#### GENERAL

- These drawings shall be read in conjunction with all other drawings and specifications of work. Specifications and work shall be subject to the provisions of the contract documents and shall be subject to the provisions of the contract documents and shall be subject to the provisions of the contract documents.
- As indicated on the drawings, the Contractor shall be responsible for obtaining all necessary permits, licenses, and approvals for the work.
- Setting out dimensions shown on the drawings shall be verified by the Surveyor.
- During construction the structure shall be maintained in a safe condition and the Contractor shall be responsible for the safety of the site and the surrounding area.
- All materials and workmanship shall be in accordance with the specifications of the SAA and NZS Codes and the relevant standards and codes of practice.
- Refer to Architectural Drawings for finish and construction details and specifications in the Contract Documents.
- The structure work shown on these drawings shall be designed for the following approximate classification for reliability:

ELEMENT	RELIABILITY RATING
Structure	AS 1753 Part 1
Foundation	AS 1753 Part 2
Floor Slab	AS 1753 Part 3

**NOTE:**  
 A 20% increase in dead load of 10kPa has been allowed for the structure work shown on these drawings. It has been assumed that the structure work is designed for a return period of 20 years.

#### CONCRETE CONT.

Refer to notes on general wall thickness and covers. The typical exposed reinforcement is as follows:

ELEMENT	MINIMUM THICKNESS (mm)	MINIMUM COVER (mm)	MINIMUM REINFORCEMENT (mm)
Slab	125	25	12
Wall	150	25	12
Column	200	25	12
Beam	200	25	12

- Slabs of concrete shall not include thickness of exposed formwork.
- Construction joints shall be in accordance with the provisions of the SAA and NZS Codes and the relevant standards and codes of practice.
- Construction joints shall be located to the approval of the Engineer.
- Slabs of concrete shall not include thickness of exposed formwork.
- Construction joints shall be in accordance with the provisions of the SAA and NZS Codes and the relevant standards and codes of practice.
- Construction joints shall be located to the approval of the Engineer.
- Slabs of concrete shall not include thickness of exposed formwork.
- Construction joints shall be in accordance with the provisions of the SAA and NZS Codes and the relevant standards and codes of practice.
- Construction joints shall be located to the approval of the Engineer.

#### REINFORCEMENT CONT.

Refer to notes on general wall thickness and covers. The typical exposed reinforcement is as follows:

ELEMENT	MINIMUM THICKNESS (mm)	MINIMUM COVER (mm)	MINIMUM REINFORCEMENT (mm)
Slab	125	25	12
Wall	150	25	12
Column	200	25	12
Beam	200	25	12

- Reinforcement shall be in accordance with the provisions of the SAA and NZS Codes and the relevant standards and codes of practice.
- Reinforcement shall be in accordance with the provisions of the SAA and NZS Codes and the relevant standards and codes of practice.
- Reinforcement shall be in accordance with the provisions of the SAA and NZS Codes and the relevant standards and codes of practice.
- Reinforcement shall be in accordance with the provisions of the SAA and NZS Codes and the relevant standards and codes of practice.
- Reinforcement shall be in accordance with the provisions of the SAA and NZS Codes and the relevant standards and codes of practice.
- Reinforcement shall be in accordance with the provisions of the SAA and NZS Codes and the relevant standards and codes of practice.
- Reinforcement shall be in accordance with the provisions of the SAA and NZS Codes and the relevant standards and codes of practice.
- Reinforcement shall be in accordance with the provisions of the SAA and NZS Codes and the relevant standards and codes of practice.
- Reinforcement shall be in accordance with the provisions of the SAA and NZS Codes and the relevant standards and codes of practice.
- Reinforcement shall be in accordance with the provisions of the SAA and NZS Codes and the relevant standards and codes of practice.

#### STEELWORK CONT.

Refer to notes on general wall thickness and covers. The typical exposed reinforcement is as follows:

ELEMENT	MINIMUM THICKNESS (mm)	MINIMUM COVER (mm)	MINIMUM REINFORCEMENT (mm)
Slab	125	25	12
Wall	150	25	12
Column	200	25	12
Beam	200	25	12

- Structural steelwork shall be in accordance with the provisions of the SAA and NZS Codes and the relevant standards and codes of practice.
- Structural steelwork shall be in accordance with the provisions of the SAA and NZS Codes and the relevant standards and codes of practice.
- Structural steelwork shall be in accordance with the provisions of the SAA and NZS Codes and the relevant standards and codes of practice.
- Structural steelwork shall be in accordance with the provisions of the SAA and NZS Codes and the relevant standards and codes of practice.
- Structural steelwork shall be in accordance with the provisions of the SAA and NZS Codes and the relevant standards and codes of practice.
- Structural steelwork shall be in accordance with the provisions of the SAA and NZS Codes and the relevant standards and codes of practice.
- Structural steelwork shall be in accordance with the provisions of the SAA and NZS Codes and the relevant standards and codes of practice.
- Structural steelwork shall be in accordance with the provisions of the SAA and NZS Codes and the relevant standards and codes of practice.
- Structural steelwork shall be in accordance with the provisions of the SAA and NZS Codes and the relevant standards and codes of practice.
- Structural steelwork shall be in accordance with the provisions of the SAA and NZS Codes and the relevant standards and codes of practice.

#### TIMBER

- Timber shall be in accordance with the provisions of the SAA and NZS Codes and the relevant standards and codes of practice.
- Timber shall be in accordance with the provisions of the SAA and NZS Codes and the relevant standards and codes of practice.
- Timber shall be in accordance with the provisions of the SAA and NZS Codes and the relevant standards and codes of practice.
- Timber shall be in accordance with the provisions of the SAA and NZS Codes and the relevant standards and codes of practice.
- Timber shall be in accordance with the provisions of the SAA and NZS Codes and the relevant standards and codes of practice.
- Timber shall be in accordance with the provisions of the SAA and NZS Codes and the relevant standards and codes of practice.
- Timber shall be in accordance with the provisions of the SAA and NZS Codes and the relevant standards and codes of practice.
- Timber shall be in accordance with the provisions of the SAA and NZS Codes and the relevant standards and codes of practice.
- Timber shall be in accordance with the provisions of the SAA and NZS Codes and the relevant standards and codes of practice.
- Timber shall be in accordance with the provisions of the SAA and NZS Codes and the relevant standards and codes of practice.

#### FOUNDATION

Foundations shall be designed for an allowable bearing capacity of 150 kPa.

ELEMENT	STRATA	ALLOWABLE BEARING CAPACITY (kPa)
All	NATURAL CLAY	150 kPa

#### CONCRETE

Concrete shall be in accordance with the provisions of the SAA and NZS Codes and the relevant standards and codes of practice.

ELEMENT	SLAB THICKNESS (mm)	MINIMUM COVER (mm)	MINIMUM REINFORCEMENT (mm)
Slab	125	25	12
Wall	150	25	12
Column	200	25	12
Beam	200	25	12

#### SLAB SYMBOL

Slab symbols shall be in accordance with the provisions of the SAA and NZS Codes and the relevant standards and codes of practice.

**STRUCTURES CHECKED FOR SAFETY & SOUNDNESS BY:**  
**Kishoree Sanjay Ram of ISOMET ENGINEERS (Pty) Ltd**  
 Chartered & Registered Professional Engineer - 100 (NZ)  
 Civil & Structural Engineering (Australia & New Zealand)  
 E: kishoree@isomet.com.au | P: 08 944 6827  
 M: 0274 381 222 | F: 08 944 6827  
 DATE: 19/02/24

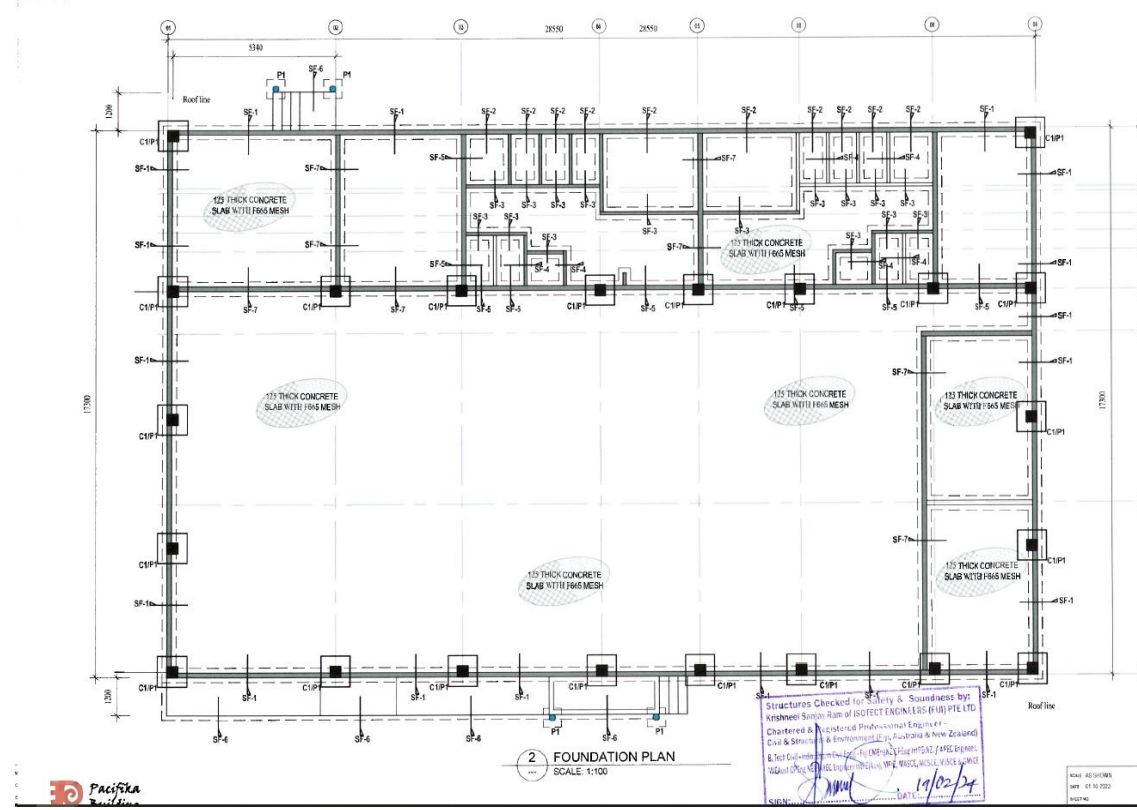

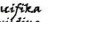
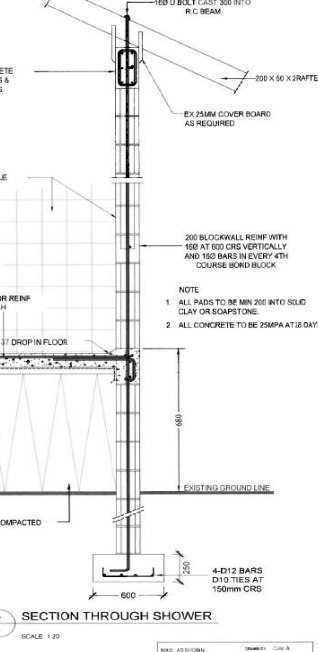
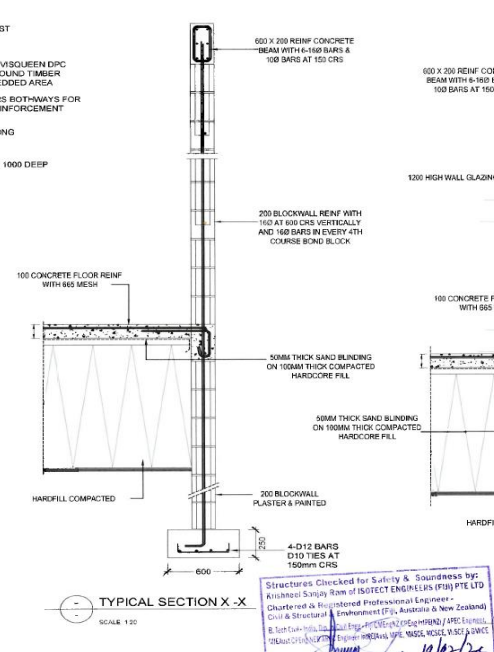
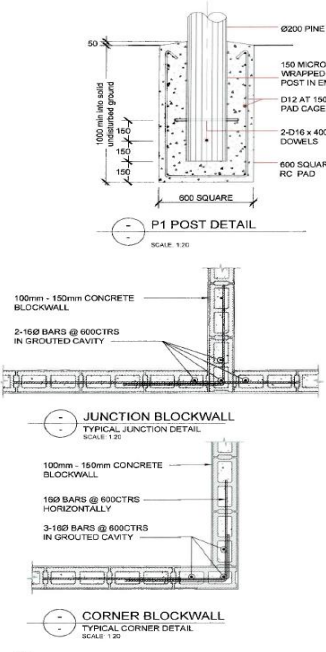
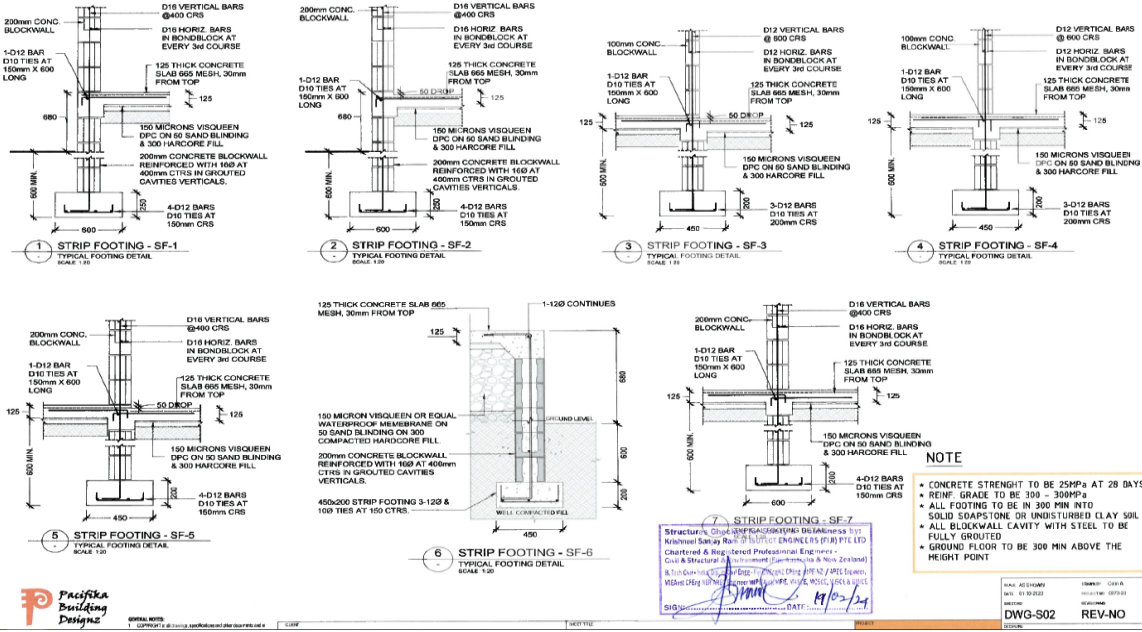

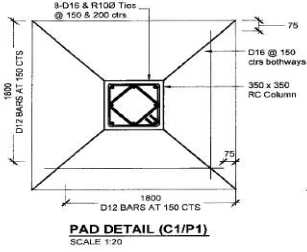
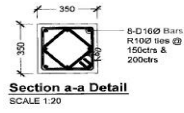

NOTE:  
LONGITUDINAL STEEL  
REINFORCEMENT FOR  
COLUMN SHALL BE  
GRADE 500MPA.

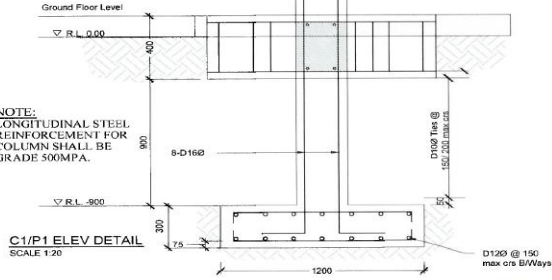

Structures Checked for Safety & Soundness by:  
Kishore Sanjay Ram of ISOTECT ENGINEERS (PVT) PTE LTD  
Chartered & Registered Professional Engineer -  
Civil & Structural & Environment (Fiji, Australia & New Zealand)  
E-Test Civil-India, Bachel. Civil Engg. (Mumbai), M.Tech. (Struct. Engg.),  
M.B.E.S.T. (Struct. Engg.), M.F.E. (Struct. Engg.), M.S.C.E. (Struct. Engg.),  
M.B.E.S.T. (Struct. Engg.), M.F.E. (Struct. Engg.), M.S.C.E. (Struct. Engg.),  
M.B.E.S.T. (Struct. Engg.), M.F.E. (Struct. Engg.), M.S.C.E. (Struct. Engg.)  
19/10/24

SCALE	1:20	REV	
DATE		BY	
ISSUED		CHK	
DWG-S04		R	



01 FLOOR PLAN  
Scale 1:100/1:200

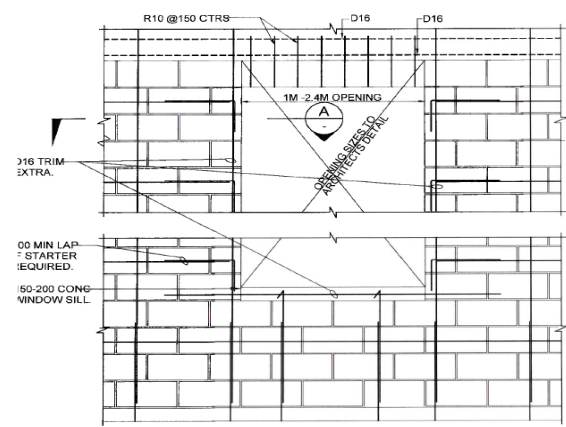

TYPICAL WINDOW OPENING DETAIL

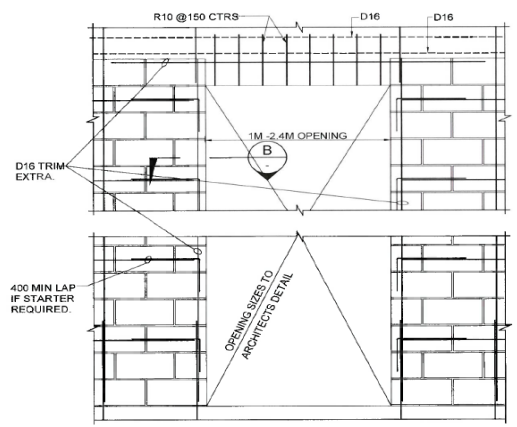

TYPICAL DOOR OPENING DETAIL

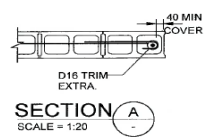

SECTION A  
SCALE = 1:20

NOTE:  
openings less than 1m are to have  
a minimum of 1/216 in lintel block  
course opening over 2.4m and not  
specifically detailed elsewhere  
are to be referred to the engineers  
for design.

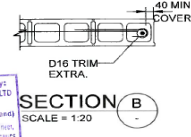

SECTION B  
SCALE = 1:20

Structures Checked for Safety & Soundness by:  
Kishore Sanjay Ram of ISOTECT ENGINEERS (PVT) PTE LTD  
Chartered & Registered Professional Engineer -  
Civil & Structural & Environment (Fiji, Australia & New Zealand)  
E-Test Civil-India, Bachel. Civil Engg. (Mumbai), M.Tech. (Struct. Engg.),  
M.B.E.S.T. (Struct. Engg.), M.F.E. (Struct. Engg.), M.S.C.E. (Struct. Engg.),  
M.B.E.S.T. (Struct. Engg.), M.F.E. (Struct. Engg.), M.S.C.E. (Struct. Engg.)  
19/10/24

SCALE	1:20	REV	
DATE		BY	
ISSUED		CHK	
DWG-S05		REV-NO	



GENERAL NOTES:  
1. ALL WORKMANSHIP TO BE IN ACCORDANCE WITH THE SPECIFICATIONS AND STANDARDS OF THE CONTRACT DOCUMENTS.



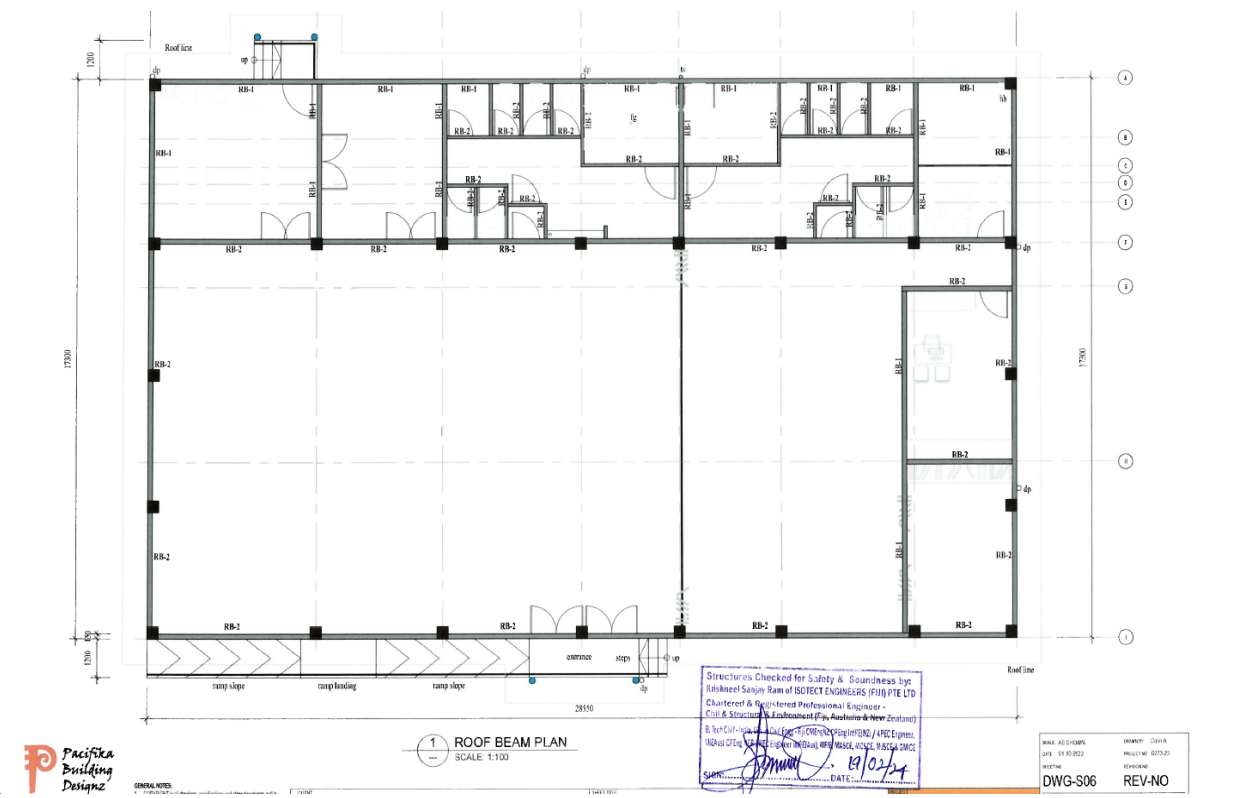
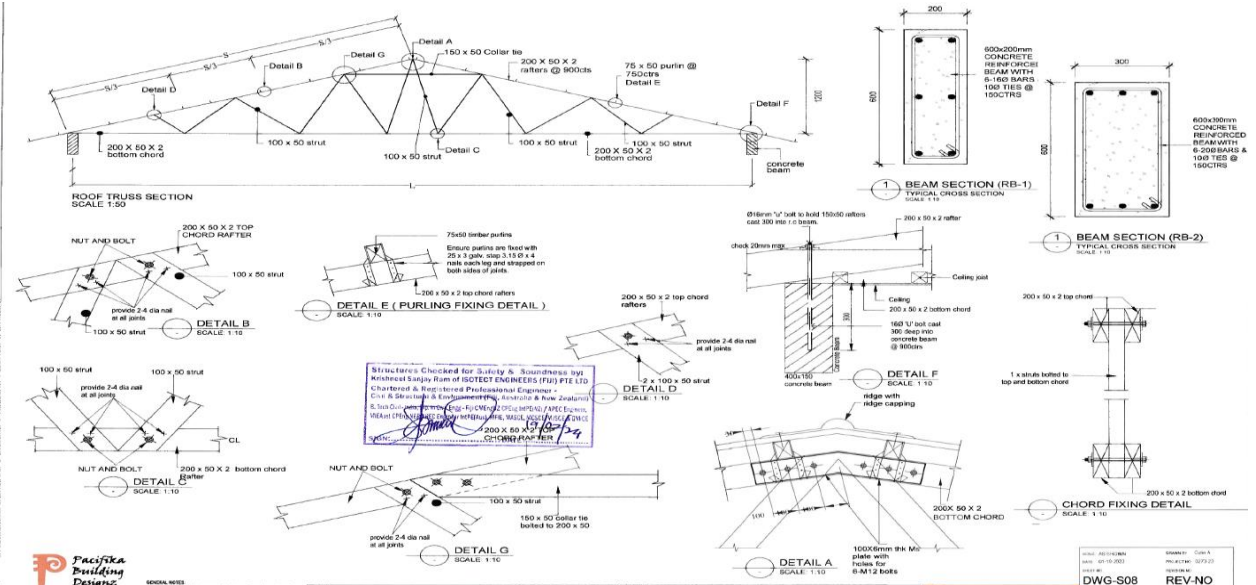



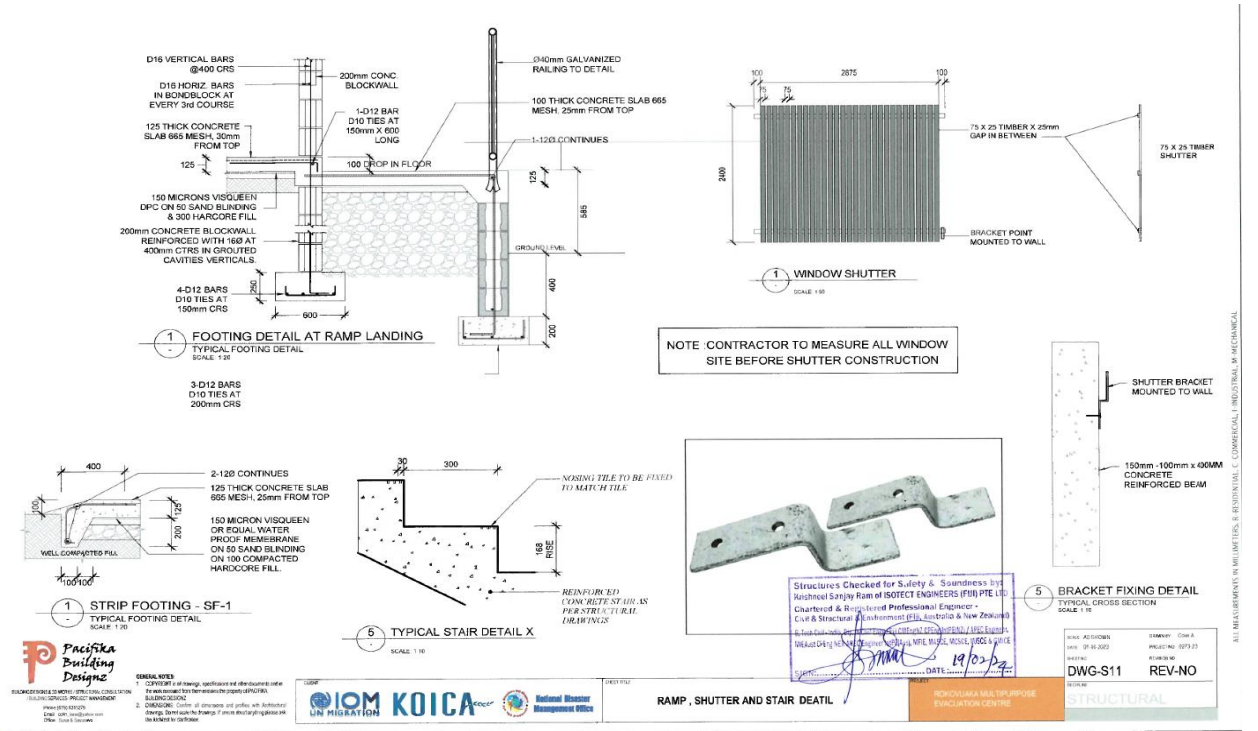
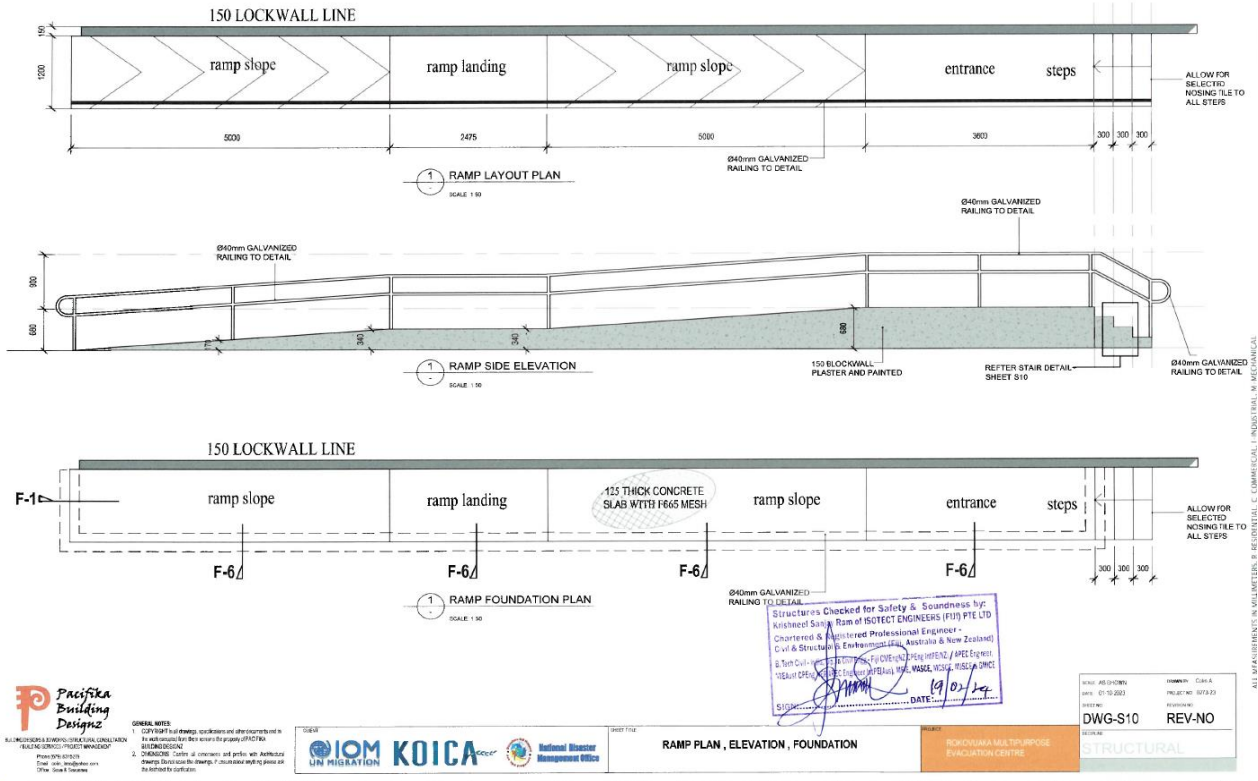



### A. Technical Specifications for Goods

ITEM	DESCRIPTION	QTY	UNIT
<b>1.000</b>			
1.001	Pine Post 200mm dia - 4.5m	2.00	lgth
1.002	cement 40 kg	270.00	bags
1.003	River Gravel	47.00	m <sup>3</sup>
1.004	Fine Sand	21.00	m <sup>3</sup>
1.005	cemestik 4 ltr	10.00	gallon
1.006	Deformed Bars 16mm	174.00	lgth
1.007	Visqueen	10.00	roll
1.008	Clout Tack 40mm	2.00	kg
1.009	Standard 200mm Block	1,960.00	no.
1.010	Deformed Bars 12mm	284.00	lgth
1.011	Deformed Bars 10mm	285.00	lgth
1.012	Binding wire 25 kg	5.00	coil
1.013	150x25mm Boxing Timber	3.00	m <sup>3</sup>
1.014	100x50mm Boxing Timber	3.00	m <sup>3</sup>
1.015	wire nail 100mm	10.00	kg
1.016	wire nail 75mm	10.00	kg
1.017	wire nail 50mm	10.00	kg
1.018	R10 Bars	83.00	lgth
<b>2.000</b>			
2.001	cement 40 kg	323.00	bags
2.002	River Gravel	58.00	m <sup>3</sup>
2.003	Fine Sand	30.00	m <sup>3</sup>
2.004	cemestik 4 ltr	8.00	gallon
2.005	665 Mesh	36.00	sht
2.006	Visqueen	10.00	roll
<b>3.000</b>			
3.100	100x50mm D/Dressed Door Frames - 6m	10.00	lgth
3.101	Galvanised nail 100mm	6.00	kg
3.102	Galvanised nail 75mm	6.00	kg
3.103	Solid core door 2200x900mm	3.00	no.
3.104	Hollow core door 2100x1000mm	9.00	no.
3.105	Hollow core door 2100x900mm	3.00	no.
3.106	Hollow core door 2100x850mm	12.00	no.
3.107	100mm butt hinge	81.00	no.
3.108	Privacy Set	24.00	no.
3.109	dead lock lockwood	1.00	no.
3.110	40x10mm Door Stop	70.00	m
3.111	Powdercoated alluminium framed egress		
3.112	door with glazing complete with locks	2.00	set
<b>4.000</b>			
4.100	Powder coated Alluminium frames with carriers		
4.200	lourve blades and fixed glass		
<b>5.000</b>			

5.100	200mm Standard Block	1,908.00	block
5.101	200mm Bond Beam	674.00	block
5.102	150mm standard block	790.00	block
5.103	150mm Bond Beam	395.00	block
5.104	cement	267.00	bag
5.105	fine sand	37.00	m <sup>3</sup>
5.106	River Gravel	28.00	m <sup>3</sup>
5.107	Deformed Bars 12mm	48.00	lgth
5.108	Deformed Bars 16mm	171.00	lgth
5.109	cement 40 kg	129.00	bags
5.110	River Gravel	23.00	m <sup>3</sup>
5.111	Fine Sand	12.00	m <sup>3</sup>
5.112	Deformed Bars 10mm	258.00	lgth
5.113	Deformed Bars 16mm	45.00	lgth
5.114	Deformed Bars 20mm	114.00	lgth
<b>6.000</b>			
6.100	200 X50mm Rafters - 6m	101.00	lgth
6.101	200 X50mm Bottom Chord - 6m	15.00	lgth
6.102	100x50mm Timber truss -6m	79.00	lgth
6.103	200 X 50mm Timber Ridge board -6m	15.00	lgth
6.104	75x50mm Timber Purlins - 6m	118.00	lgth
6.105	280 x 28mm D/Dressed Fascia Board -6m	17.00	lgth
6.106	50x50mm Ceiling Nodgging - 6m	290.00	lgth
6.107	Pryda Strapping 30m	12.00	coil
6.108	Colorbond Ridge Cap	90.00	m
6.109	26g Corrugated trimdeck roofing iron	522.00	m <sup>2</sup>
6.110	Double sided sisalation	522.00	m <sup>2</sup>
6.111	Roof screws type 17	5,950.00	no.
6.112	M12 bolt & nut 150mm	565.00	no.
6.113	Down pipe 150mm - 6m	11.00	lgth
6.114	Down pipe clip	33.00	no.
6.115	150mm pvc bend	22.00	no.
6.116	Roof & gutter silicone	12.00	tubes
6.117	Vent cawl 50mm	8.00	no.
6.118	Panel pin	8.00	kg
6.119	Galvanised nail 100mm	8.00	kg
6.120	Galvanised nail 75mm	8.00	kg
6.121	Galvanised nail 50mm	8.00	kg
6.122	plyboard 6mm	185.00	sht
6.123	150x50mm collar tie timber - 6m	14.00	lgth
6.124	6mm gable end plate with holes	33.00	no.
6.125	Colorbond gutter	99.00	m
6.126	Gutter Nozzle	11.00	no.
6.127	Clout Tack nail - 40mm	10.00	kg
6.128	Gutter strap - 2m	12.00	lgth
6.129	M12 bolt & nut 150mm for splice	195.00	no.
<b>7.000</b>			
7.100	50x50mm Ceiling Nodgging - 6m	19.00	lgth

7.101	plyboard 6mm	20.00	sht
7.102	Towerbolt 100mm	19.00	no.
7.103	Panel pin	4.00	kg
7.104	Galvanised nail 100mm	6.00	kg
<b>8.000</b>			
8.101	Toilet Pan	8.00	no.
8.102	Toilet Cistern	8.00	no.
8.103	Toilet seat w/ cover - black	8.00	no.
8.104	Toilet Roll holder	8.00	no.
8.105	Double bowl stainless steel sink	1.00	no.
8.106	shower cubicle complete set	2.00	no.
8.107	Vanity Hand Basin complete	2.00	no.
8.108	shower rose with arm	6.00	no.
8.109	Flexible hose 400mm	8.00	no.
8.110	Stop cock 15mm	16.00	no.
8.111	Floor grating 80mm	5.00	no.
8.112	swivel tap for kitchen sink	1.00	no.
8.113	15mm Pipe	15.00	lgth
8.114	15mm Plain Socket	20.00	no.
8.115	15mm Faucet Socket	20.00	no.
8.116	15mm 'T' Junction	15.00	no.
8.117	15mm elbow	25.00	no.
8.118	50mm PVC Pipe	8.00	lgth
8.119	Combination S & P Trap	3.00	no.
8.120	50mm Plain Socket	10.00	no.
8.121	50mm elbow	10.00	no.
8.122	50mm Faucet Socket	10.00	no.
8.123	50mm 'T' Junction	10.00	no.
8.124	150mm U PVC Pipe	17.00	lgth
8.125	150mm Plain socket	10.00	no.
8.126	150mm elbow 90°	8.00	no.
8.127	150mm 'T' Junction	6.00	no.
8.128	pvc Glue 1000ml	3.00	tin
8.129	80mm Grab rail for disable toilet	2.00	set
8.130	150mm Terminal vent	6.00	no.
8.131	150mm gully trap	3.00	no.
<b>9.000</b>			
9.101	Mounting block	50.00	pcs
9.102	Single switch	10.00	pcs
9.103	Double GPO 10 amps	27.00	pcs
9.104	Single GPO 10 amps	6.00	pcs
9.105	weatherproof GPO IP53	5.00	pcs
9.106	No. 2 cable clip	3.00	pkts
9.107	Power point wire	600.00	mtr
9.108	Light wire	600.00	mtr
9.109	Switch wire	400.00	mtr
9.110	36watts Fluorescent weatherproof luminare	31.00	pcs

9.111	with led 24 watts Fluorescent tubes		
9.109	36watts Fluorescent luminare w / Prismatic	38.00	pcs
9.110	Difusser with led 24 watts Fluorescent tubes		
9.111	18watts Fluorescent luminare w / Prismatic	5.00	pcs
9.112	Difusser with led 11 watts Fluorescent tubes		
9.113	weatherproof		
9.114	36watts Fluorescent luminare w / Battery pk	12.00	pcs
9.115	with led 24 watts Fluorescent tubes		
9.116	10 watts non maintained emergency exit	3.00	pcs
9.117	running man single exist sign		
9.118	LED Flood Light 50 watts	4.00	pcs
9.119	25mm saddle	1.00	doz
9.120	25mm conduit	2.00	lgth
9.121	16mm highdrawn wire	20.00	mtr
9.122	No.1 aerial clamp	2.00	pcs
9.123	FEA nut & bolt	1.00	pcs
9.124	Entry box	1.00	pcs
9.125	20mm conduit	3.00	lgth
9.126	20mm saddle	2.00	doz
9.127	20mm adaptor locknut	1.00	pcs
9.128	6mm pvc red wire	10.00	mtr
9.129	6mm pvc black wire	10.00	mtr
9.130	6mm pvc green wire	10.00	mtr
9.131	Earth clip	1.00	pcs
9.132	Earth rod	1.00	pcs
9.133	10A ELCB with cover	1.00	pcs
9.134	16A ELCB with cover	1.00	pcs
9.135	Two meter board	1.00	pcs
9.136	5/32 machine screw & nut	2.00	doz
<b>10.000</b>			
10.101	Exterior Undercoat 10 ltr	10.00	gallon
10.102	Exterior Painting 20 ltr	6.00	gallon
10.103	Interior Undercoat 10 ltr	4.00	gallon
10.104	Interior Painting 20 ltr	6.00	gallon
10.105	door & frames 20 ltr	2.00	gallon
10.106	Fascia boards & posts 20 ltr	2.00	gallon
10.107	Eaves Battens 20 ltr	5.00	gallon
10.108	Ceiling 20 ltr	6.00	gallon
10.109	Paint Brush 100mm	20.00	no.
10.110	Paint Brush 50mm	10.00	no.
10.111	Roller tray with handles	10.00	no.
10.109	Roller sleeves	10.00	no.
10.110	Thinner 4ltr	2.00	no.
10.111	Turpentine 4 ltr	2.00	no.
10.112	P80 Sand paper	20.00	m
10.113	P100 Sand Paper	20.00	no.
<b>11.000</b>			

11.100	Kitchen joinery including cabinets, Fitouts	1.00	
11.101	Admin office joinery and Library Room	1.00	
<b>12.000</b>			
12.001	40mm Galvanised Pipe - 5.8m	8.00	lgth
12.002	cutting disk 100mm	4.00	no.
12.003	grinding disk 100mm	2.00	no.
12.004	welding electrodes 12kg	1.00	pkt
12.005	cement 40 kg	70.00	bags
12.006	River Gravel	13.00	m <sup>3</sup>
12.007	Fine Sand	8.00	m <sup>3</sup>
<b>13.000</b>			
13.001	600X600mm Anti slip floor tiles	520.00	no.
13.002	Tile adhesive 20 kg	33.00	bag
13.003	Tile grout 10 kg	12.00	bag
<b>14.000</b>			
14.001	D10 Bars	4.00	lgth
14.002	cement	4.00	bags
14.003	Gravel	1.00	m <sup>3</sup>
14.004	fine sand	1.00	m <sup>3</sup>
14.005	100mm Block	120.00	no.
<b>15.000</b>			
15.001	150mm standard block	166.00	no.
15.002	100mm standard block	210.00	no.
15.003	D12 Bars	14.00	no.
15.004	Cement	20.00	no.
15.005	Gravel	5.00	m <sup>3</sup>
15.006	Fine sand	3.00	m <sup>3</sup>
15.007	Binding wire 10 kg	1.00	coil
15.008	665 mesh 2.4x5.8m	2.00	sht
15.009	coral for soakage pits (2 different sites)	10.00	heaps
15.010	Peforated pipe	10.00	m
<b>16.000</b>			
16.001	75X25mm Timber Shutters (6m)	120.00	lgth
16.002	Shutter bracket	52.00	no.
16.003	Dyna bolt 100mm	105.00	no.
16.004	Galvanised nail 75mm	6.00	kg
<b>17.000</b>			
17.001	Cement	60.00	bags
17.002	Gravel	12.00	m <sup>3</sup>
17.003	fine sand	6.00	m <sup>3</sup>
17.004	665 Mesh	7.00	sht

## B. Technical Specification

### GENERAL

1. These drawings shall be used in conjunction with all Architectural and Structural Drawings. Specifications and notes shall apply to the drawings. Any discrepancy shall be referred to the Supervisor for approval before proceeding with the work.

2. All dimensions are in millimeters. Dimensions shall NOT be rounded off. Dimensions shall be given to the nearest millimeter. Dimensions shall be given to the nearest millimeter unless otherwise specified.

3. Details not shown in the drawings shall be as per the relevant standards and specifications.

4. Details not shown in the drawings shall be as per the relevant standards and specifications.

5. All workmanship and materials shall be in accordance with the requirements of the relevant building authorities.

6. Details for Structural Drawings for each wall and foundation shall be provided in the Structural Drawings and shall be in accordance with the relevant standards and specifications.

7. The structure shown on these drawings has been designed for the following approximate classification for durability:

ELEMENT	DESIGN RESISTANCE RATING
Concrete	R20
Steel	R20

8. The structure shown on these drawings has been designed for the following approximate classification for durability:

FLOOR USAGE	LEVEL (D.M.M)
Ground Floor	0.00
First Floor	1.20

**NOTE:**  
 1. Reinforcement shall be provided in all concrete elements.  
 2. The structure shall be designed in accordance with the relevant standards and specifications.  
 3. The structure shall be designed in accordance with the relevant standards and specifications.

### FOUNDATION

1. The foundation shall be designed for the following approximate classification for durability:

ELEMENT	DESIGN RESISTANCE RATING
Concrete	R20
Steel	R20

### CONCRETE CONT.

Reinforcement shall be provided in all concrete elements. The reinforcement shall be in accordance with the relevant standards and specifications.

ELEMENT	DESIGN RESISTANCE RATING
Concrete	R20
Steel	R20

### REINFORCEMENT

1. Reinforcement shall be provided in all concrete elements. The reinforcement shall be in accordance with the relevant standards and specifications.

BAR SIZE	MINIMUM SPACING	MAXIMUM SPACING
10mm	100mm	250mm
12mm	100mm	250mm
16mm	100mm	250mm
20mm	100mm	250mm

### STEELWORK CONT.

1. Steelwork shall be provided in all concrete elements. The steelwork shall be in accordance with the relevant standards and specifications.

ELEMENT	DESIGN RESISTANCE RATING
Steel	R20

### BLOCKWORK

1. Blockwork shall be provided in all concrete elements. The blockwork shall be in accordance with the relevant standards and specifications.

ELEMENT	DESIGN RESISTANCE RATING
Blockwork	R20

### TIMBER

1. Timber shall be provided in all concrete elements. The timber shall be in accordance with the relevant standards and specifications.

ELEMENT	DESIGN RESISTANCE RATING
Timber	R20

### DRAFTING ABBREVIATIONS

SYMBOL	DESCRIPTION
1	10mm
2	12mm
3	16mm
4	20mm

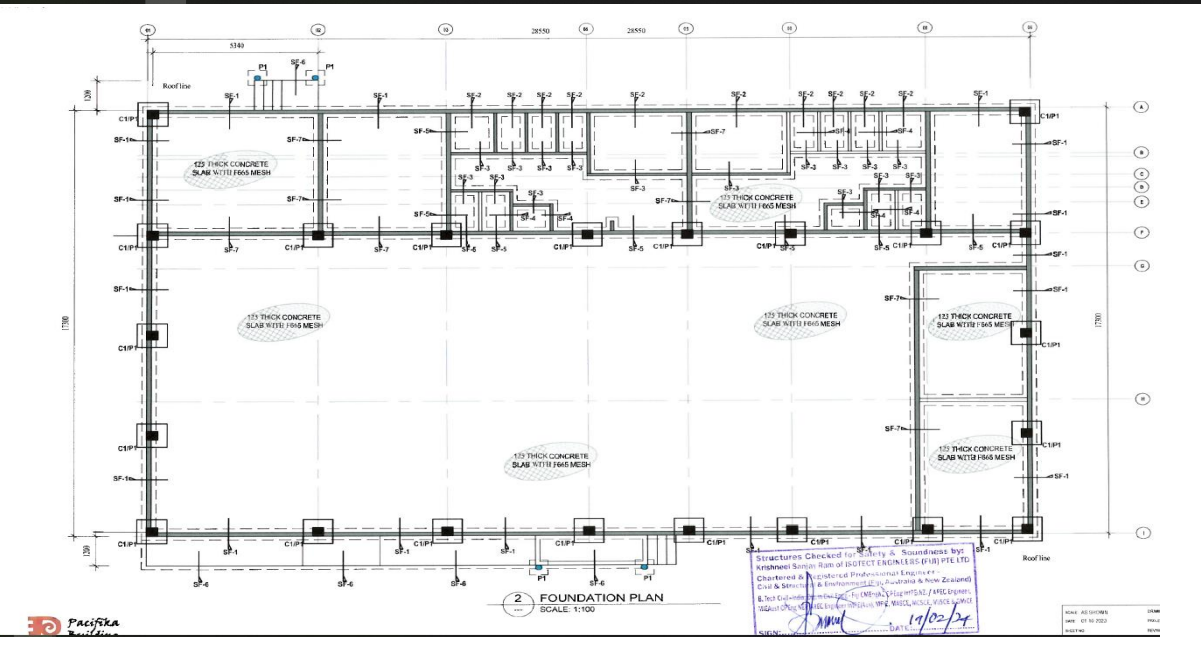



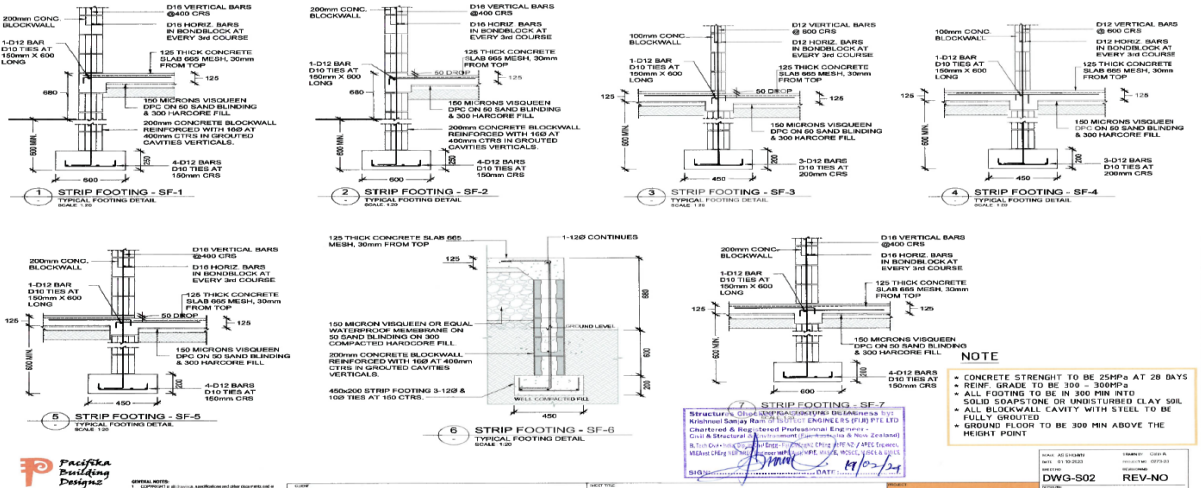

- CONCRETE STRENGTH TO BE 25MPa AT 28 DAYS
REF. GRADE TO BE 300 - 300MPa
ALL FOOTING TO BE IN 300 MM INTO SOLID SOAPSTONE OR UNDISTURBED CLAY SOL.
ALL BLOCKWALL CAVITY WITH STEEL TO BE FULLY GROUTED
GROUND FLOOR TO BE 300 MM ABOVE THE HEIGHT POINT

Structures Checked for Safety & Soundness by:
Rishabh Sanjay Ram of STRUCT ENGINEERS (PVT) LTD
Chartered & Registered Professional Engineer -
Civil & Structural Engineering (P.E., Australia & New Zealand)
E. Sanjay Ram of STRUCT ENGINEERS (PVT) LTD
Chartered & Registered Professional Engineer -
Structural Engineering (P.E., Australia & New Zealand)
19/10/24

Pacificka Building Designs

DWG-S02 REV-NO

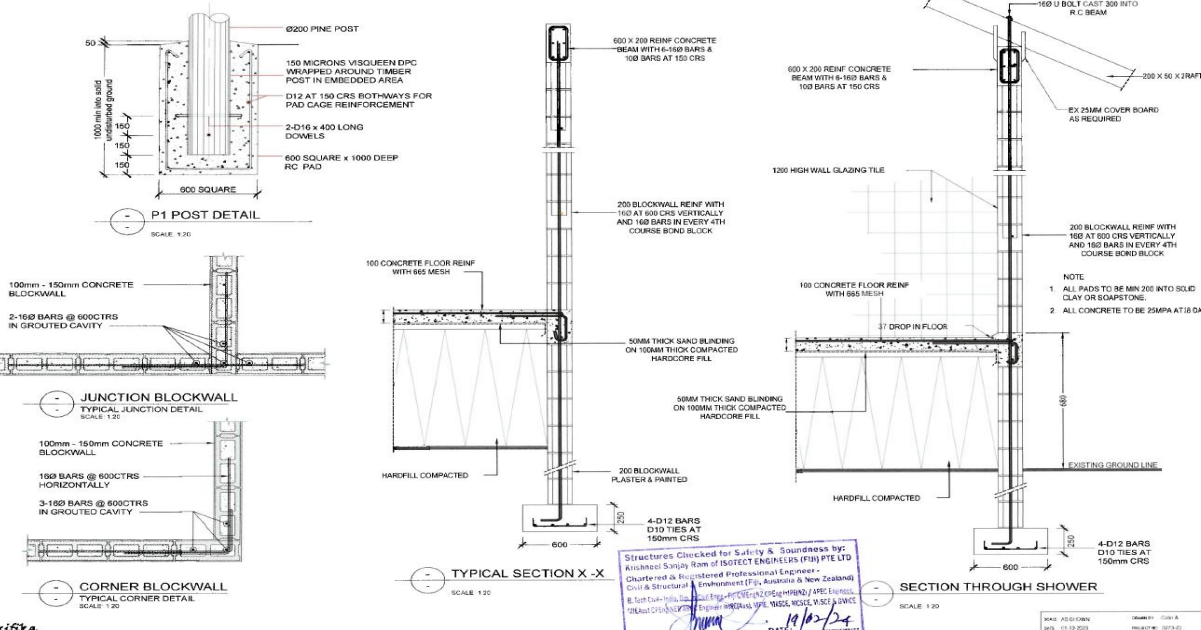

- ALL PADS TO BE 300 MM INTO SOLID CLAY OR SOAPSTONE.
ALL CONCRETE TO BE 25MPa AT 28 DAYS

Structures Checked for Safety & Soundness by:
Rishabh Sanjay Ram of STRUCT ENGINEERS (PVT) LTD
Chartered & Registered Professional Engineer -
Civil & Structural Engineering (P.E., Australia & New Zealand)
E. Sanjay Ram of STRUCT ENGINEERS (PVT) LTD
Chartered & Registered Professional Engineer -
Structural Engineering (P.E., Australia & New Zealand)
19/10/24

Pacificka Building Designs

DWG-S04

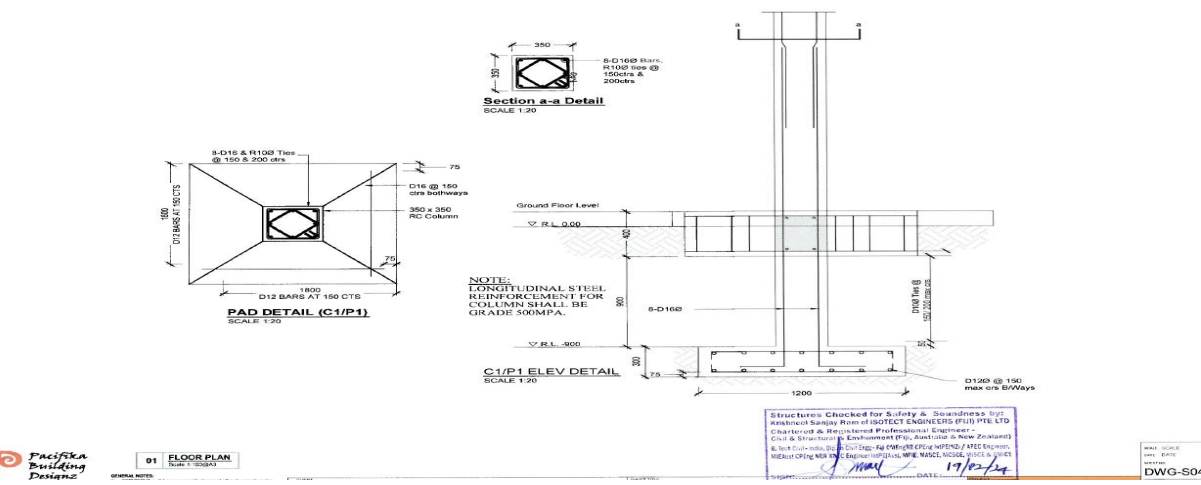

NOTES: LONGITUDINAL STEEL REINFORCEMENT FOR COLUMN SHALL BE GRADE 500MPa.

Structures Checked for Safety & Soundness by:
Rishabh Sanjay Ram of STRUCT ENGINEERS (PVT) LTD
Chartered & Registered Professional Engineer -
Civil & Structural Engineering (P.E., Australia & New Zealand)
E. Sanjay Ram of STRUCT ENGINEERS (PVT) LTD
Chartered & Registered Professional Engineer -
Structural Engineering (P.E., Australia & New Zealand)
19/10/24

Pacificka Building Designs

DWG-S04

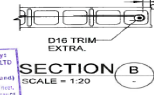
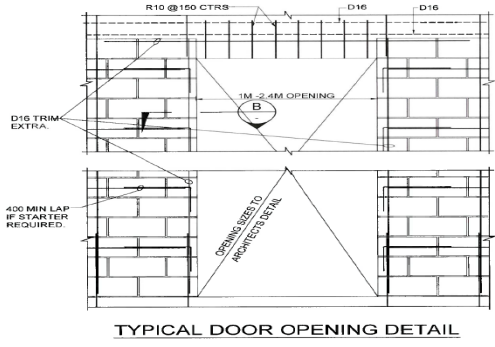
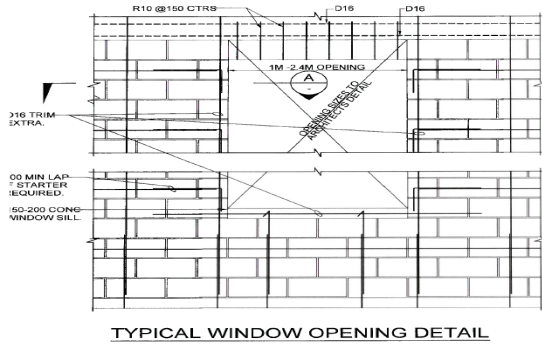

**NOTE:** Openings less than 1m are to have a minimum of 1/16 in inset block course opening over 2.4m and not specifically detailed elsewhere are to be referred to the relevant section for design.

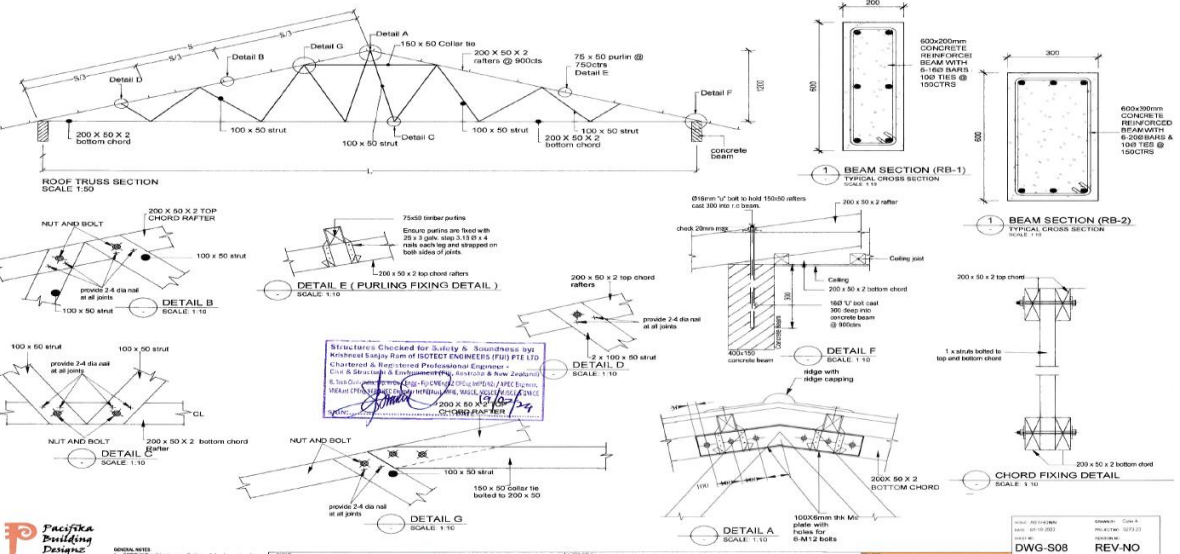

Structures Checked for Safety & Soundness by:  
Rafiqul Haque, B.Sc. (Hons) B.Eng. (Hons) FICE FIE FIE  
Chartered & Registered Professional Engineer -  
Civil & Structural & Environment (E.P., Auditor & New Zealand)  
E. P. Haque, B.Sc. (Hons) B.Eng. (Hons) FICE FIE FIE  
Chartered & Registered Professional Engineer -  
Civil & Structural & Environment (E.P., Auditor & New Zealand)  
E. P. Haque, B.Sc. (Hons) B.Eng. (Hons) FICE FIE FIE  
Chartered & Registered Professional Engineer -  
Civil & Structural & Environment (E.P., Auditor & New Zealand)

DWG-S06 REV-NO



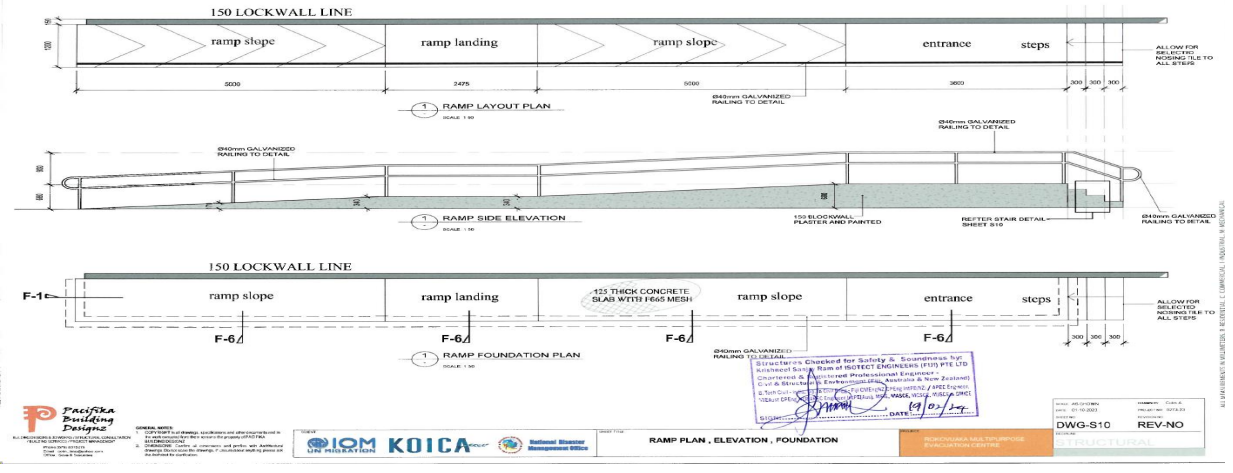
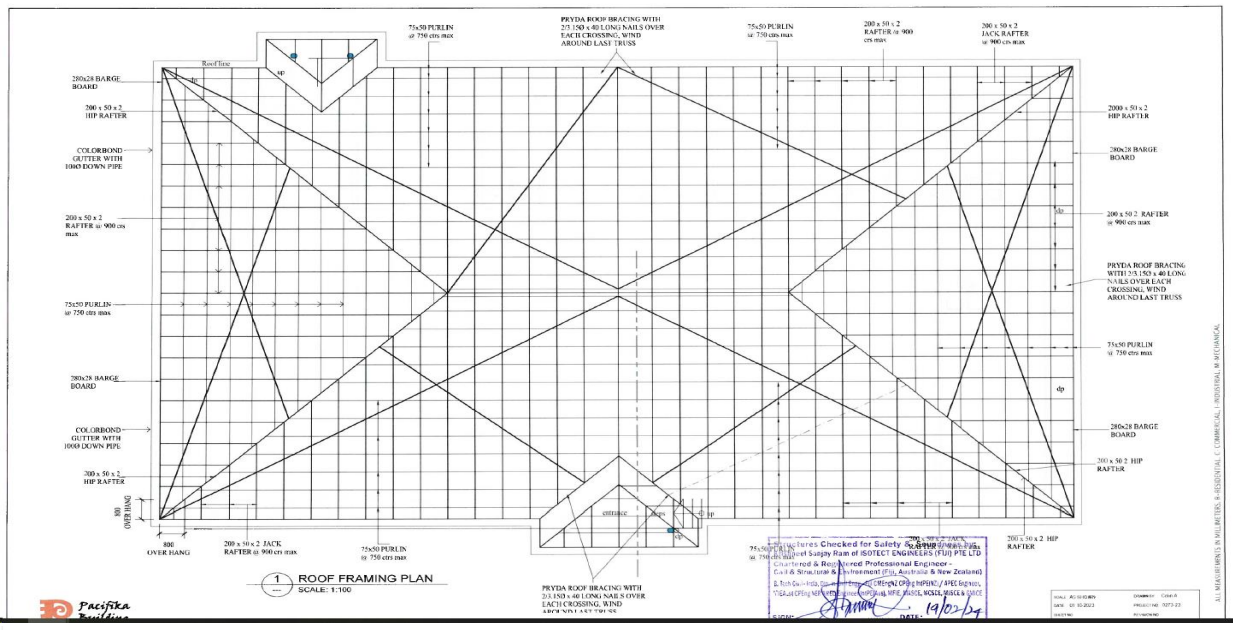
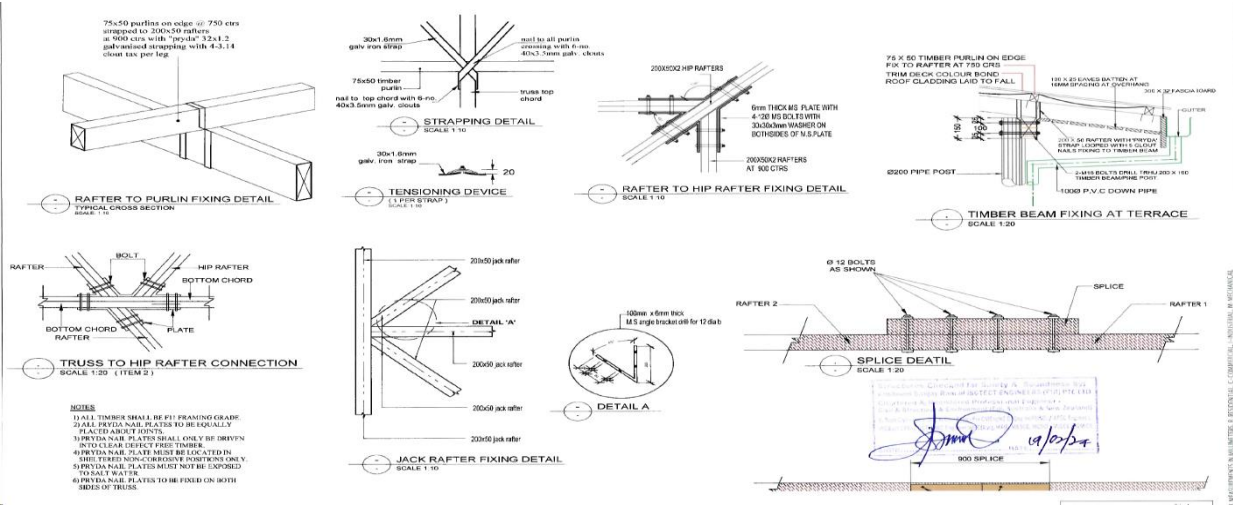

**Pacificika Building Design**

**IOM KOICA**

**UN Migration Agency**

**RAMP PLAN, ELEVATION, FOUNDATION**

**DWG-S10 REV-NO**

**STRUCTURAL**

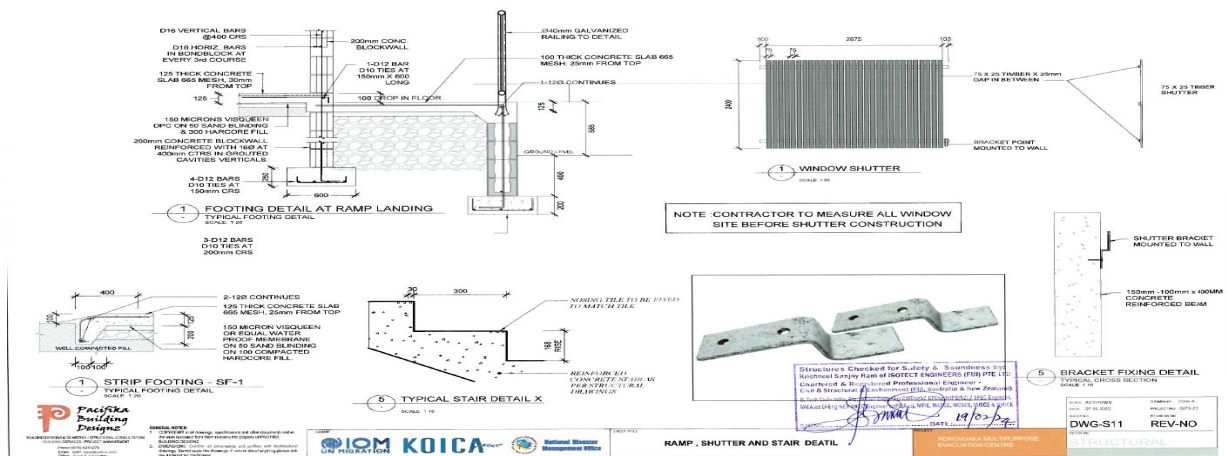

### C. Delivery Requirements

<b>Delivery date</b>	Bidder shall deliver the goods and services as soon as possible preferably within 3 months after contract signature.
<b>Delivery place/terms (INCOTERMS 2020)</b>	Rokovoka, Nalawa, Ra.

<b>Customs clearance (must be linked to INCOTERM)</b>	<input type="checkbox"/> Not applicable Shall be done by: <input type="checkbox"/> Click or tap here to enter text. <input checked="" type="checkbox"/> <b>Supplier/Bidder</b> <input type="checkbox"/> Freight Forwarder
<b>Consignee details</b>	IOM Fiji
<b>Distribution of shipping documents (if using freight forwarder)</b>	n/a
<b>Packing requirements</b>	n/a
<b>Mode of transport</b>	<input type="checkbox"/> Air <input type="checkbox"/> Sea <input checked="" type="checkbox"/> <b>Land</b> <input type="checkbox"/> Other specify

### D. Inspections and tests

- Site Visitation will be done every fortnight to see the process of work as per plan and scope of work, inspecting the time frame given by the vendor.
- Inspection will be done with engineer, project manager and Procurement personal when applicable.

## **SECTION 6: CONDITIONS OF CONTRACT AND CONTRACT FORMS**

### 6.1 Contract Form with General Conditions of Contract

**CONSTRUCTION AGREEMENT**  
**between the**  
**International Organization for Migration**  
**and**  
[Name of the Contractor]

This Construction Agreement is entered into between the **International Organization for Migration**, a related organization of the United Nations, acting through its [insert office name, e.g., Mission in XXX], [Address of the Mission], represented by [Name, Title of Director, CoM, HoO] (hereinafter referred to as “**IOM**”), and [**Name of Contractor**], of [address], in [country], represented by [Name, Title of the representative of the Contractor], (hereinafter referred to as the “**Contractor**”). IOM and the Contractor are also referred to individually as a “**Party**” and collectively as the “**Parties**.”

#### **1. Introduction and Integral Documents**

- 1.1 IOM intends to engage the services of [Contractor] in connection with [name of project] located at [address] (the “**Project**”). As part of the Project, IOM requires the Contractor to perform construction services, on the terms and conditions specified in this Agreement.
- 1.2 The following documents form part of this Agreement: *[add/delete as necessary]*
- (a) **Annex A** - Scope of Work, Technical Specifications, and Drawings (the “**Works**”);
  - (b) **Annex B** - Bill of Quantities (including Unit Cost);
  - (c) **Annex C** - Approved Work Schedule;
  - (d) **Annex D** - Advance Payment Bank Guarantee Template
  - (e) **Annex E** – Performance Security Template;
  - (f) **Annex F** - Work Variation Order Template; and
  - (g) **Annex G** – IOM Terms and Conditions for European Union Funded Service Type Agreements

In the event of conflict between the provisions of any Annex and the terms of the main body of the Agreement, the latter shall prevail.

- 1.3 All correspondence, instructions, notes and other communications relating in any way to the performance of this Agreement will be in the English language. The English language version of the Agreement will at all times be the version of the Agreement which binds the Parties. Translations of the Agreement into languages other than English may be prepared for working purposes but will have no legally binding effect on the Parties.
- 1.4 Unless otherwise advised by IOM in writing, all Project reports and other issues arising under this Agreement shall be addressed to IOM’s authorized contact person under Article 21 of this Agreement.

#### **2. Scope of Work**

- 2.1 The Contractor shall furnish all the necessary materials, tools and equipment, labor, supervision, and other services, for the satisfactory and timely completion of the Works in accordance with this Agreement.
- 2.2 Any changes, modifications, deviations and substitutions in the Works shall require prior written approval by IOM and shall be made in accordance with Article 7 (“**Work Variation**”).
- 2.3 In case necessary, IOM reserves the right to supply any materials, equipment or resources for the Works. Any adjustment to the total Contract Price arising from IOM’s actions under this clause shall be agreed in writing pursuant to Article 7 of this Agreement.

### 3. Contract Price

- 3.1 The total contract price (the “**Contract Price**”) shall be [currency code] [amount in numbers] ([amount in words]) only, inclusive of all applicable fees, taxes and permits that may be imposed by any Government entity in connection with the execution, completion, and turnover of the Works pursuant to this Agreement.
- 3.2 The Contract Price and Unit Cost (as stated in the Bill of Quantities) shall not be altered except where Article 2.3 or Article 7 applies.
- 3.3 In consideration for the services performed under this Agreement, the total amount payable by IOM to the Contractor pursuant to this Agreement shall not exceed the Contract Price, regardless of any increase in wage or labor cost or fluctuation in the cost of materials and equipment, occurring at any time. For the avoidance of doubt, the Contractor shall be liable for any under-estimation of the requirements of this Agreement and any changes in costs whether due to inflation, currency devaluation or otherwise.

### 4. Manner of Payment

- 4.1 In consideration for the services performed under this Agreement, IOM shall pay the Contract Price in accordance with the following payment schedule:
  - (a) (Applicable if an advance payment is made) IOM shall release an advance payment equivalent to [percentage] of the Contract Price in the amount of [currency] [insert amount in numbers] (amount in words and currency in words) within 7 (seven) calendar days from the Contractor’s signature of this Agreement and Contractor’s submission of and IOM’s approval of the following items:
    - i. Drawings and Technical Documents for Permit Purposes;
    - ii. Approved Detailed Construction and Workings Drawings;
    - iii. Work Schedule;
    - iv. List of Sub-Contractors and Suppliers (if applicable);
    - v. Unconditional Bank Guarantee equivalent to [percentage to match advance payment] percent of the Contract Price to guarantee the advance payment, if applicable;
    - vi. Performance Security if required under Article 9.
  - (b) IOM will pay the Contractor [currency code] amount in numbers (amount in words) on confirmation by IOM of satisfactory progress toward the completion of (amount)%

([amount in words] percent) actual measured work as per Bill of Quantities at Annex B and logbook.

- (c) IOM will pay the Contractor [currency code] amount in numbers (amount in words) after the completion of 100% (one hundred percent) of the Works and inspection and provisional acceptance of the completed Works.
- (d) The balance of 10% (ten percent) of the total Contract Price in the amount of [currency code] amount in numbers (amount in words) will be held for 12 (twelve) months after provisional acceptance of the completed Works in accordance with Article 10 of this Agreement.

4.2 Payments for the Works will be done in installments in accordance with the Payment Schedule above in [currency] ([currency code]) by [bank transfer] to the following bank account:

Bank Name:	
Bank Branch:	
Bank Account Name:	
Bank Account Number:	
Swift Code:	
IBAN Number:	

Any change to the bank account shall be formalized by an amendment to this Agreement.

4.3 The Contractor's progress billing shall be submitted to and certified by IOM's appointed Project Manager who will verify the value of the work done with regard to the value of the quantities of items completed in the Bill of Quantities. The Contractor shall submit all progress billing with the following attachments:

- (a) Updated Financial Statement of the Project;
- (b) Statement of Completed Works;
- (c) Progress Photos; and
- (d) Contractor's Sales Invoice.

4.4 Within 7 (seven) calendar days of Contractor's submission of the progress billing and Statement of Completed Works and all required attachments to the Project Manager, the Project Manager shall evaluate the said progress billing(s). Evaluated and approved progress billings shall be due and payable within 10 (ten) working days from date of approval of progress billing. During this period of evaluation and processing of payments, the Contractor shall continue progress of the work in accordance with the Approved Work Schedule.

4.5 Any payment(s) made by IOM does not imply nor signify acceptance of any portion of the Works and does not waive IOM's right to enforce the Contractor's warranty as provided in Article 14.2 of this Agreement, nor to apply penalties for delay.

4.6 The Contractor can only submit the final progress billing as per the Payment Schedule when the Contractor has satisfactorily completed and submitted:

- (a) All works, including Work Variation Orders, as stipulated in the annexed documents;
- (b) Rectification of all reported non-conforming works;
- (c) Completed demobilization and clean-up of site;

- (d) Applicable materials and work test certificate/s;
- (e) Approval duly signed by the Project Manager and by the Contractor's authorized representative that the Work is completed in accordance with drawings and specifications and in compliance with applicable laws, rules and regulations of the local and/or national government of the location where the Project is to be implemented.

4.7 A Certificate of Provisional Acceptance of completed Works shall be issued by IOM when each of the requirements under Article 4.6 have been fulfilled to its satisfaction.

4.8A Certificate of Provisional Acceptance of terminated Works shall be issued by IOM if IOM terminates the contract in accordance with Article 26. This Certificate will indicate the Completion Rate as per Article 6.2 and the Contractor shall remain responsible for the rectification of non-conforming or defective portions of the Works in accordance with Article 14.2.

4.9A Certificate of Final Acceptance shall be issued by IOM 12 (twelve) months after the date a Certificate of Provisional Acceptance of the completed or terminated Works is issued provided that any works required during the warranty period have been completed to its satisfaction.

## 5. Completion Period

- 5.1 The Contractor shall mobilize all necessary and appropriate resources and coordinate all work activities with IOM to ensure commencement of the Works on [insert date] and completion and turn-over of the Works to IOM by [insert date] ("**Completion Date**").
- 5.2 If the Contractor is unable to complete the Works by the Completion Date, the Contractor may request a time extension in writing explaining the reasons for the delay. Any adjustment to the costs of performance security, or extension of required insurances, for the performance of the Works due to such time extension shall be for the account of the Contractor.
- 5.3 IOM shall not approve requests for time extension for reasons such as but not limited to:
- (a) Project location, conditions and restrictions identified during time of tender and award of the Agreement;
  - (b) Normal weather and climatic conditions prevailing at the site location;
  - (c) Logistics, implementation, coordination problems and other reasons within the control of the Contractor;
  - (d) Financial, operational and labor difficulties of the Contractor or any of its sub-contractor(s) or supplier/s;
  - (e) Any required rectification of non-conforming work items; and
  - (f) Nature and condition of terrain.
- 5.4 IOM may, at its sole discretion, revise the Completion Date as stated in Article 5.1 in response to the Contractor's reasonable request for time extension caused by any of the following:
- (a) Force Majeure as described in Article 16;
  - (b) Approved Work Variation Order/s requiring additional time for completion by the Contractor, as agreed between the Parties;
  - (c) IOM's failure to make timely payments for the Works completed to IOM's satisfaction.
- 5.5 IOM shall be entitled to charge liquidated damages equivalent to 0.1% (one-tenth of one



percent) of the total Contract Price for each day of delay until the entire Works are completed and accepted by IOM according to Article 4.7. IOM may, at its sole discretion, grant a conditional time extension whereby the Works are not considered to be in delay during the time extended, but in case of non-completion within the extended period, the calculation of liquidated damages for delay outlined herein shall be from the original Completion Date before extension. If the Agreement is terminated by either Party after the Completion Date (before extension) due to non-completion of the Works, the Contractor shall be liable to IOM for liquidated damages equivalent to 0.1% (one-tenth of one percent) of the total Contract Price for each day from the Completion Date (before extension) to the notice date of termination.

## 6. Work Schedule

- 6.1 Within the timeframe specified in the Notice of Award (NoA) and no later than the date of signature of this Agreement, the Contractor shall submit to IOM a work schedule (the “**Work Schedule**”) showing the order and timing for all the activities in the Works.
- 6.2 The Contractor shall keep and update a daily logbook on all progress and matters relating to the Works in accordance with industry standards. The logbook shall be inspected and verified for accuracy, daily or at an interval designated by IOM, by a designated IOM staff or its authorized representatives. The logbook shall be the authoritative source of information for determining the extent of the Works completed (the “**Completion Rate**”). In case the Contractor fails to update the logbook properly with the required verification, IOM shall have the right to solely determine the Completion Rate which cannot be challenged by the Contractor.
- 6.3 The Contractor shall submit an updated Work Schedule as and when requested by IOM or its Project Manager.
- 6.4 The Contractor shall notify IOM through its Project Manager of any proposed change in the Work Schedule. Any change shall be subject to prior written approval by IOM. The Contractor shall also submit to the Project Manager for approval a revised schedule within 7 (seven) calendar days from the date of proposing the change.
- 6.5 If at any time IOM deems that Contractor’s actual progress is inadequate to meet the requirements of this Agreement, IOM may notify the Contractor to take such steps as may be necessary to improve its progress. If after a reasonable period, as determined by IOM, the Contractor still does not improve its performance, IOM may require an increase in Contractor’s labour force, the number of shifts, workdays per week, overtime hours, amount of equipment, or require expedited shipment of equipment and materials, all at the Contractor’s cost and without additional cost to IOM.
- 6.6 If at any time the Contractor’s labor force is inactive due to unpaid wages, the Contractor shall be liable to IOM for liquidated damages equivalent to 0.1% (one-tenth of one percent) of the total Contract Price for each day of work stoppage until the entire labor force resumes work on the Project. This penalty shall be applied independently of any other sanction or penalty allowed for in this Agreement.

## 7. Work Variation

- 7.1 IOM reserves the right at any time to order any variations, alterations or modifications in the



scope of work, technical specification, or drawings relating to the Works, as specified under Annex A herein, which are deemed necessary or appropriate by IOM in the best interest of the Project (“**Work Variation**”).

- 7.2. The Contractor shall, within ten (10) calendar days from receipt of notice of Work Variation from IOM, confirm in writing to IOM the impact of the Work Variation on the Contract Price, Payment Schedule, Work Schedule and Completion Date, if any.
- 7.3. If any work in the Work Variation corresponds with an item description in the Bill of Quantities, the rate in the Bill of Quantities shall be used to calculate the value of the Work Variation. In other cases, the cost of such Work Variation shall be evaluated and compensated as agreed between the Parties. In such case, the Contractor shall provide IOM a quotation for the cost of the Work Variation.
- 7.4. All Work Variations shall be in writing based on agreed terms by the Parties, and shall be covered by a work variation order (the “**Work Variation Order**”) based on the template in Annex F of this Agreement. The Contractor shall immediately implement the terms of the Work Variation Order as agreed by the Parties.
- 7.5. All Work Variation Orders duly signed by both Parties shall automatically form part of this Agreement without need of further amendment, except in the following cases:
- a. In case the increase in the Contract Price exceeds USD 100,000, or exceeds 20% (twenty percent) of the original amount of Contract Price; or
  - b. In case the increase in the Contract Price brings the total aggregate contract value to USD 200,000 or more.

In these cases, a written amendment between Parties shall be required for such changes to form part of this Agreement.

- 7.6. Under no circumstances shall the Work Variation Order be used to modify or amend any portion of this Agreement not covered under Articles 7.1 and 7.2 above.

## **8. Bank Guarantee for Advance Payment (IF APPLICABLE)**

The Contractor shall provide IOM with a bank guarantee to secure the requested advance payment (the “**Bank Guarantee**”) in an amount equivalent to the total amount advanced to be issued by a reputable bank or financial entity acceptable to IOM, based on the template in Annex D, or as otherwise accepted by IOM in writing. The Bank Guarantee shall be effective from the date of the release of cash advance as per Article 4.1 of this Agreement until the date of the provisional acceptance as per Articles 4.7 or 4.8, following which the Bank Guarantee will be released by IOM. IOM shall not be obliged to make any advance payment until the Bank Guarantee is received and approved by IOM. The amount of the Bank Guarantee shall not be construed as the limit of the Contractor’s liability to IOM in any event.

## **9. Performance Security (Applicable where the contract price is over USD 300,000)**

The Contractor shall provide IOM with a performance security in the amount equivalent to 10% (ten percent) of the Contract Price, to be issued by a reputable bank or surety company, based on the template in Annex E or in a form acceptable to IOM (the “**Performance Security**”). The Performance Security shall serve as the guarantee for the Contractor’s satisfactory performance and compliance

with the terms and conditions of this Agreement. The amount of the Performance Security shall not be construed as the limit of the Contractor's liability to IOM in any event. The Performance Security shall be effective from the date of commencement of the Works until the date of Provisional Acceptance as per Articles 4.7 or 4.8 following which it will be discharged by IOM.

## 10. Retention

10.1 Upon issuance of the Certificate of Provisional Acceptance for completed Works as per Article 4.7, an amount equivalent to 10% (ten percent) of the Contract Price shall be retained by IOM ("**Retention Amount**"), to be used for repairs or reconstruction of defective works due to poor workmanship and/or inferior quality of material used which are discovered within a period of 12 (twelve) months from the date of Provisional Acceptance ("**Retention Period**").

10.2 In case a Certificate of Provisional Acceptance for terminated Works has been issued as per Article 4.8, an amount equivalent to 10% (ten percent) of the Contract Price corresponding to the Completion Rate as per Article 6.2 shall be retained by IOM as Retention Amount, to be used for repairs and reconstruction of defective works due to poor workmanship and/or inferior quality of material used for which the Contractor was responsible under this Agreement which are discovered within a period of 12 (twelve) months from the date of Provisional Acceptance.

10.3 The Contractor may, from the date of Provisional Acceptance and until the expiration of Retention Period, request IOM to release the amount retained as per Article 10.1 or Article 10.2 by submitting an unconditional bank guarantee. Such bank guarantee shall be in a form and by a bank acceptable to IOM and in an amount and currency equal to the amount retained and effective until the expiration of Retention Period.

## 11. Contractor's Responsibility

11.1 All government permits and licenses required for the execution of the Works under this Agreement shall be obtained prior to the commencement of the Works and paid for by the Contractor.

11.2 The Contractor shall comply with local and national building regulations imposed by appropriate government agencies, and shall keep IOM indemnified against all fines, penalties and losses incurred by reason of any breach of this clause.

11.3 The Contractor shall assume full responsibility for the Works under this Agreement until its final acceptance by IOM as per Article 4.9. The Contractor shall have entire control and supervision of the Works and services herein agreed upon and shall be solely liable for the salaries, wages and other employment benefits of all employees and sub-contractors. Should the Contractor breach this clause, IOM has the right to proceed against the Performance Bond or Bank Guarantee or to use the Retention Amount, without prejudice to demanding direct reimbursement from the Contractor in the event that the amount of the Performance Bond Bank Guarantee or Retention Amount is insufficient.

11.4 The Contractor shall be responsible for the safety of all activities on the site and for ensuring that relevant occupational health and safety laws and regulations are followed.

11.5 The Contractor shall be solely and fully accountable for any claim for losses, liabilities, injuries, or damages arising out of or in connection with the work done or to be performed under this

Agreement including but not limited to any accident or injury of any of its employees or sub-contractors during the term of this Agreement , or for any injury to any person or damages or loss of properties arising from the construction or any act or omission of the Contractor or anyone in its employment, or its subcontractors.

- 11.6 The Contractor shall comply with local laws on wages and such other labor laws including all other laws, orders and regulations of any government authority in connection with the Works.
- 11.7 The Contractor shall at all times defend, indemnify, and hold harmless IOM, its officers, employees, and agents from and against all losses, costs, damages and expenses (including legal fees and costs), claims, suits, proceedings, demands and liabilities of any kind or nature to the extent arising out of or resulting from acts or omissions of the Contractor or its employees, officers, agents or subcontractors, in the performance of this Agreement. IOM shall promptly notify the Contractor of any written claim, loss, or demand for which the Contractor is responsible under this clause.

## **12. Inspection of Works**

- 12.1 IOM reserves the right for itself and its representatives to inspect the Works, while in progress, so as to give IOM the opportunity to reject the whole or any portion thereof, which in the opinion of IOM's representative is defective or substandard.
- 12.2 The Contractor shall allow the Project Manager and other IOM representatives to access to the work site at any time.

## **13. Insurance**

- 13.1 Without limiting the Contractor's liability pursuant to Article 11 (Contractor's Responsibility), the following insurance cover is to be provided and maintained by the Contractor for the entire duration of this Agreement:
- (a) Third party liability for any one claim or series of claims arising out of any one accident or event;
  - (b) Workmen's compensation and/or employer's liability insurance which complies with applicable legislation;
  - (c) Automobile public liability and property damage insurance; and
  - (d) Cover against loss or damage to the Works and materials during the construction.
- 13.2 The amount of coverage for each type of insurance is to be in line with relevant industry standards and in an amount acceptable to IOM.
- 13.3 Policies and certificates of insurance are to be provided to IOM prior to the commencement of the Works.

## **14. Warranties**

- 14.1 The Contractor represents and warrants that it is financially sound and duly licensed, with the adequate labor/human resources, equipment and tools, competence, expertise and skills necessary to carry out fully and satisfactorily, within the stipulated completion period, the Works in accordance with this Agreement.

- 14.2 The Contractor guarantees and warrants the performance and completion of the design and construction work to the full and complete satisfaction of IOM. The Contractor remains responsible for the damages caused or identified within 12 (twelve) months from the date of issue of IOM's Certificate of Provisional Acceptance of the Works as per Articles 4.7 or 4.8, on account of defects in the construction, or the use of materials of inferior quality furnished by it, or due to any violation of the terms of the Agreement.
- 14.3 Any work re-performed by, or any rework, repair or replacement done in satisfaction of the Contractor's obligations in relation to its warranty under this Agreement, shall automatically be re-warranted by Contractor for additional 12 (twelve) months from the completion and provisional acceptance of the rework, repair, or replacement.
- 14.4 In case of any defect in workmanship or materials, which may become apparent in the course of construction, the Contractor shall, within 7 (seven) calendar days from IOM's demand, at Contractor's own cost and expense, remedy such portion of the Works done by the Contractor as in the opinion or judgment of IOM is unsound, incorrect or defective or not in accordance with the plans and specifications.
- 14.5 In case of Contractor's default, failure or refusal to carry out such order to remove and replace the unsound, incorrect or defective portion of the Works within 7 (seven) days as required by the previous clause, IOM may terminate this Agreement and/or engage the services of other persons to carry out the same. The Contractor shall bear all expenses arising there from or incidental thereto. IOM may require direct reimbursement for the cost of such action from the Contractor, deduct the expenses from any amount due to the Contractor, or deduct the amount from Performance Bond, the Bank Guarantee or the Retention Amount.
- 14.6 If any defects or imperfections are discovered by IOM and communicated to the Contractor after provisional acceptance but prior to final acceptance of the Works due to defective or improper workmanship and/or inferior quality of the material used, the Contractor shall immediately correct such defects within a period of 5 (five) days of receipt of written notice from IOM. Where the Contractor fails to act within this period, IOM may engage the services of a third party to correct the defect and hold the Contractor liable for the cost of such services. In such circumstances the Contractor shall reimburse IOM the cost of such repair, with interest at 2% (two percent) per month from the time such expenses were incurred until fully reimbursed. The Performance Bond, Bank Guarantee and Retention Amount, if not yet released at the time the said defects are found, may be used for this purpose.
- 14.7 The Contractor shall perform repair work with the utmost care and diligence to protect existing facilities and prevent damage thereto. In the event that damage to existing facilities is caused by such repairs, the Contractor shall repair such damage at its own expense and to IOM's satisfaction and acceptance.
- 14.8 The Contractor further warrants that:
- (a) It shall comply with all applicable laws, ordinances, rules and regulations when performing its obligations under this Agreement;
  - (b) In all circumstances it shall act in the best interests of IOM;
  - (c) No official or employee of IOM or any third party has received from, will be offered by, or will receive from the Contractor any direct or indirect benefit arising from the Agreement or award thereof;
  - (d) It has not misrepresented or concealed any material facts in the procuring of this Agreement;

- (e) All materials used are new, legally sourced and fit for their particular purpose;
- (f) No asbestos or any other health hazard materials (lead paints etc.) will be used in the course of the construction;
- (g) The Contractor, its staff or shareholders have not previously been declared by IOM ineligible to be awarded agreements by IOM;
- (h) It will maintain reasonable and appropriate organizational, administrative, physical, and technical safeguards to ensure the integrity and confidentiality of the information shared pursuant to this Agreement. The safeguards shall be designed to protect against any foreseeable threats or risks to the security and integrity of such information as well as the unauthorized access, use or disclosure thereof. If requested by IOM at any time during the term of this Agreement, the Contractor shall provide IOM with copies of its policies, protocols, records, and other relevant materials implementing the safeguards;
- (i) The Contract Price specified in this Agreement shall constitute the sole remuneration in connection with this Agreement. The Contractor shall not accept for its own benefit any trade commission, discount or similar payment in connection with activities pursuant to this Agreement or the discharge of its obligations thereunder. The Contractor shall ensure that any subcontractors, as well as the officers, personnel and agents of either of them, similarly, shall not receive any such additional remuneration;
- (j) It shall respect the legal status, privileges and immunities of IOM as an intergovernmental organization, such as inviolability of documents and archive wherever it is located, exemption from taxation, immunity from legal process or national jurisdiction. In the event that the Contractor becomes aware of any situation where IOM's legal status, privileges or immunities are not fully respected, it shall immediately inform IOM;
- (k) It is not included in the most recent United Nations Security Council Consolidated List nor is it the subject of any sanctions or other temporary suspension. The Contractor will disclose to IOM if it becomes subject to any sanction or temporary suspension during the term of this Agreement;
- (l) It must not employ, provide resources to, support, contract or otherwise deal with any person, entity or other group associated with terrorism as per the most recent United Nations Security Council Consolidated List and all other applicable anti-terrorism legislation. If, during the term of this Agreement, the Contractor determines there are allegations or suspicions that funds transferred to it in accordance with this Agreement have been used to provide support or assistance to individuals or entities associated with terrorism, it will inform IOM immediately who in consultation with the donors as appropriate, shall determine an appropriate response. The Contractor shall ensure that this requirement is included in all subcontracts.

14.9 The Contractor warrants that it shall abide by the highest ethical standards in the performance of this Agreement, which includes not engaging in any fraudulent, corrupt, discriminatory or exploitative practice or practice inconsistent with the rights set forth in the Convention on the Rights of the Child. The Contractor shall immediately inform IOM of any allegation or suspicion that the following practice may have occurred or exist:

- (a) fraudulent practice, defined as any act or omission, including misrepresentation or concealment, that knowingly or recklessly misleads, or attempts to mislead, a natural or legal person in the procurement process or the execution of a contract party to obtain a financial gain or other benefit, or to avoid an obligation or in such a way as to cause a detriment to IOM;
- (b) corrupt practice defined as the offering, giving, receiving or soliciting, directly or indirectly, of anything of value to influence improperly the actions of another natural

or legal person in the procurement process or in contract execution, such as through bribery;

- (c) collusive practice defined as an arrangement between two or more bidders, or other natural or legal persons designed to achieve an improper purpose, including influencing improperly the actions of another natural or legal person or artificially altering the results of the procurement process to obtain a financial gain or other benefit;
- (d) coercive practice defined as impairing or harming, or threatening to impair or harm, directly or indirectly, any natural or legal person or the property of any such person to influence improperly its actions or impact the execution of a contract;
- (e) obstructive practice defined as acts or omissions intended to materially impede the exercise of IOM's contractual rights of audit, investigation and/or access to information, including deliberately destroying, falsifying, altering or concealing of evidence material to IOM investigations, or making false statements to IOM investigators in order to materially impede a duly authorized investigation into allegations of fraudulent, corrupt, collusive, coercive or unethical practices; and/or threatening, harassing or intimidating any party to prevent it from disclosing its knowledge of matters relevant to the investigation or from pursuing the investigation;
- (f) unethical practice defined as a practice contrary to the IOM Unified Staff Regulations and Rules or UN Supplier Code of Conduct, such as those relating to conflict of interest, gifts, hospitality, post-employment provisions, abuse of authority, harassment, discriminatory or exploitative practices or practices inconsistent with the rights set forth in the Convention on the Rights of the Child;
- (g) money laundering practice defined as the conversion or transfer of property knowing that such property is derived from any offence(s), for the purpose of concealing or disguising the illicit origin of the property or of assisting any persons who are involved in such offence(s) to evade the legal consequences of their actions. Property shall include, but not be limited to money.

14.10 The Contractor further warrants that it shall:

- (a) Take all appropriate measures to prevent sexual exploitation and sexual abuse (SEA), as those terms are defined in section 1 of ST/SGB/2003/13 (the "SG Bulletin"),<sup>1</sup> and sexual harassment (SH), as that term is defined in section 1 of the UN System Model Policy on Sexual Harassment,<sup>2</sup> by its employees or sub-contractors, consultants, interns or volunteers associated with or working on behalf of the Contractor to perform activities under this Agreement ("Associated Personnel");
- (b) accept and follow the standards of conduct listed in section 3 of the SG Bulletin;
- (c) Promptly and confidentially report to IOM any allegations or suspicions of SEA or SH concerning its employees or Associated Personnel; promptly investigate any credible allegations of SEA or SH concerning its employees or Associated Personnel, and inform IOM of the outcome of such investigation; take appropriate corrective measures, including imposing disciplinary measures on any of its employees or Associated Personnel who has committed SEA or SH, and inform IOM of such corrective measures;
- (d) Provide to IOM, on written request, all relevant information to determine whether the Contractor has taken appropriate investigative and corrective action in cases of

---

<sup>1</sup> Secretary-General's Bulletin Special measures for protection from sexual exploitation and sexual abuse dated 9 October 2003, [N0355040.pdf \(un.org\)](#)

<sup>2</sup> UN System Model Policy on Sexual Harassment, [CEB Model Policy \(unsceb.org\)](#)



- SEA or SH. Failure to take appropriate investigative or corrective action to the satisfaction of IOM shall constitute material breach of this Agreement;
- (e) Ensure that the SEA and SH provisions contained in this Article are included in all sub-contracts related to this Agreement;
  - (f) Adhere to the provisions of this Article for the duration of this Agreement.
- 14.11 The Contractor expressly acknowledges and agrees that breach by the Contractor, its employees or its Associated Personnel, of any provision contained in Articles 14.8, 14.9, or 14.10 of this Agreement constitutes a material breach of this Agreement and shall entitle IOM to terminate this Agreement immediately on written notice without liability. In the event that IOM determines, whether through an investigation or otherwise, that such a breach has occurred then, in addition to its right to terminate the Agreement, IOM shall be entitled to recover from the Contractor all losses suffered by IOM in connection with such breach.
- 14.12 IOM shall have the right to investigate any allegations (including but not limited to SEA, SH, fraud and corruption) involving the Contractor, its employees or its Associated Personnel, notwithstanding related investigations undertaken by the Contractor or national authorities. The Contractor shall provide its full and timely cooperation with any such investigations. Such cooperation shall include, but shall not be limited to, the Contractor's obligation to make available its personnel and any relevant documentation for such purposes at reasonable times and on reasonable conditions and to grant access to the Contractor's premises at reasonable times and on reasonable conditions in connection with such access to the Contractor's personnel and relevant documentation. The Contractor shall require its agents, including, but not limited to, the Contractor's attorneys, accountants or other advisers, to reasonably cooperate with any such investigations carried out by IOM.
- 14.13 The Contractor's warranty obligation under this Agreement shall remain valid and existing during the warranty period, notwithstanding the handover of the Works by IOM to a third-party, and the Contractor shall remain liable to IOM for any defects in the construction, workmanship, use of substandard materials, or any violation of the terms of the Agreement during such warranty period.

## **15. Assignment and Subcontracting**

- 15.1 The Contractor shall not assign or subcontract the Agreement or any work under this Agreement in whole or in part, unless agreed in writing in advance by IOM. Any subcontract entered into by the Contractor without approval in writing by IOM may be cause for termination of the Agreement.
- 15.2 Notwithstanding a written approval from IOM, the Contractor shall not be relieved of any liability or obligation under this Agreement nor shall it create any contractual relation between any subcontractor and IOM. The Contractor shall include in an agreement with a subcontractor all provisions in this Agreement that are applicable to a subcontractor, including relevant Warranties and Special Provisions, if any. The Contractor remains liable as a primary obligor under this Agreement, and it shall be directly responsible to IOM for any faulty performance under any subcontract. The subcontractor shall have no cause of action against IOM for any breach of the sub-contract.

## **16. Force Majeure**

- 16.1 Neither Party will be liable for any delay in performing or failure to perform any of its



obligations under this Agreement if such delay or failure is caused by force majeure, which means any unforeseeable and irresistible act of nature, any act of war (whether declared or not), invasion, revolution, insurrection, terrorism, blockade or embargo, strikes, Governmental or state restrictions, natural disaster, epidemic, public health crisis, and any other circumstances which are not caused by nor within the control of the affected Party.

- 16.2 As soon as possible after the occurrence of a force majeure event which impacts the ability of the affected Party to comply with its obligations under this Agreement, the affected Party will give notice and full details in writing to the other Party of the existence of the force majeure event and the likelihood of delay. On receipt of such notice, the unaffected Party shall take such action as it reasonably considers appropriate or necessary in the circumstances, including granting to the affected Party a reasonable extension of time in which to perform its obligations. During the period of force majeure, the affected Party shall take all reasonable steps to minimize damages and resume performance.
- 16.3 IOM shall be entitled without liability to suspend or terminate the Agreement if Contractor is unable to perform its obligations under the Agreement by reason of force majeure. In the event of such suspension or termination, the provisions of the Article on Termination shall apply.

## **17. Intellectual Property**

All intellectual property and other proprietary rights including, but not limited to, patents, copyrights, trademarks, and ownership of data resulting from the performance of the Services shall be vested in IOM, including, without any limitation, the rights to use, reproduce, adapt, publish and distribute any item or part thereof.

## **18. Independent Contractor**

The Contractor, its employees and other personnel as well as its subcontractors and their personnel, if any, shall perform all Works under this Agreement as an independent contractor and not as an employee or agent of IOM.

## **19. Audit**

The Contractor agrees to maintain records, in accordance with sound and generally accepted accounting procedures, of all direct and indirect costs of whatever nature involving transactions related to the provision of services under this Agreement. The Contractor shall make all such records available to IOM or IOM's designated representative at all reasonable times until the expiration of 7 (seven) years after the date of final payment, for inspection, audit, or reproduction. On request, employees of the Contractor shall be available for interview.

## **20. Confidentiality**

- 20.1 All information which comes into the Contractor's possession or knowledge in connection with this Agreement is to be treated as strictly confidential. The Contractor shall not communicate such information to any third party without the prior written approval of IOM. The Contractor shall comply with IOM Data Protection Principles in the event that it collects, receives, uses, transfers, stores or otherwise processes any personal data in the performance of this Agreement. This obligation shall survive the expiration or termination of this Agreement.

- 20.2 Notwithstanding the previous paragraph, IOM may disclose the terms of this Agreement and information related to this Agreement, including the name of the Contractor, the title of the contract/project, the nature and purpose of the contract/project, and the amount of the contract/project to the extent required by its donor/s or auditors in relation to IOM's commitment to any initiative for transparency and accountability of funding received by IOM provided that such disclosure will be in accordance with the policies, instructions and regulations of IOM.

## 21. Notices

Any notice given pursuant to this Agreement will be sufficiently given if it is in writing and received by the other Party at the following address:

**International Organization for Migration (IOM)**

Attn: [Name and title/position of IOM contact person]

[IOM's address]

Email: [IOM's email address]

**[Full name of the Contractor]**

Attn: [Name and title/position of the Contractor's contact person]

[Contractor's address]

Email: [Contractor's email address]

## 22. Dispute Resolution

- 22.1 Any dispute, controversy or claim arising out of or in relation to this Agreement, or the breach, termination or invalidity thereof, shall be settled amicably by negotiation between the Parties.
- 22.2 In the event that the dispute, controversy or claim is not resolved by negotiation within 3 (three) months of receipt of the notice from one Party of the existence of such dispute, controversy or claim, either Party may request that it be submitted to mediation in accordance with the UNCITRAL Mediation Rules in effect at the time of the dispute.
- 22.3 In the event that mediation is not successful, either Party may submit the dispute, controversy or claim to arbitration in accordance with the UNCITRAL Arbitration Rules in effect at the time of the dispute no later than 3 (three) months following the date of termination of the mediation as per Article 9 of the UNCITRAL Mediation Rules. The number of arbitrators shall be one and the language to be used in the arbitral proceedings shall be English. The appointing authority shall be the Secretary General of the Permanent Court of Arbitration. The arbitral tribunal shall have no authority to award punitive damages. The seat of the arbitration shall be Geneva, Switzerland.
- 22.4 All aspects of the dispute resolution as per paragraphs 1 to 3 of this Article shall be treated as confidential by the Parties and all others involved.
- 22.5 The present Agreement as well as the arbitration agreement above shall be governed by the terms of the present Agreement and supplemented by internationally accepted general principles of law (including the UNIDROIT Principles of International Commercial Contracts) for issues not covered by the Agreement, to the exclusion of any single national system of law that would defer the Agreement to the laws of any given jurisdiction.

22.6 This Article survives the expiration or termination of the present Agreement.

### **23. Use of IOM Name, Abbreviation and Emblem**

The Contractor shall not be entitled to use the name, abbreviation or emblem of IOM without IOM's prior written authorisation. The Contractor acknowledges that use of the IOM name, abbreviation and emblem is strictly reserved for the official purposes of IOM and protected from unauthorized use by Article 6<sup>ter</sup> of the Paris Convention for the Protection of Industrial Property, revised in Stockholm in 1967 (828 UNTS 305 (1972)).

### **24. Status of IOM**

Nothing in or relating to this Agreement shall be deemed a waiver, express or implied, of any of the privileges and immunities of the International Organization for Migration.

### **25. No Waiver Clause**

IOM's failure to insist upon a strict performance of any of the terms and conditions of this Agreement shall not be deemed a relinquishment of any right or remedy that IOM may have, nor shall it be construed as a waiver of Contractor's subsequent breach of this Agreement which shall continue to be in full force and effect. No waiver by IOM of any of its rights under this Agreement shall be deemed to have been made unless expressed in writing and signed by IOM.

### **26. Termination of Agreement**

26.1 IOM may, at its option, terminate for convenience any of the work under this Agreement in whole or in part, at any time by 7 (seven) days written notice to Contractor. Such notice shall specify the Completion Rate upon termination as established by Article 6.2 and the effective date of termination. Upon receipt of such notice Contractor shall:

- (a) Immediately discontinue the Works on the date and to the extent specified in the notice and place no further purchase orders or subcontracts for materials, services, or facilities other than as may be required for completion of such portion of the Works that is not terminated;
- (b) Promptly cancel upon terms satisfactory to IOM all purchase orders, subcontracts, rentals, or any other agreement existing for the performance of the terminated work, or assign those agreements as directed by IOM;
- (c) Assist IOM in the maintenance and protection of work in progress, plant, tools, equipment, property and materials acquired by Contractor or furnished by IOM under this Agreement;
- (d) Complete performance of such portion of the Works which are not terminated; and
- (e) Perform other related tasks, which IOM may reasonably instruct, in order to effect the termination of the work.

26.2 Upon termination as per the previous clause, as the sole right and remedy of Contractor, IOM shall pay in accordance with the following:

- (a) The Contract Price corresponding to the Works performed in accordance with this Agreement prior to the date of such notice of termination;
- (b) Costs corresponding to the portion of the Works thereafter performed as specified in such notice of termination, subject to IOM's acceptance of such part of the Works;

- (c) Reasonable and documented administrative costs of settling and paying claims arising out of the termination of work under purchase orders or subcontracts, as agreed by IOM; and
- (d) Reasonable costs incurred in demobilization and the disposition of residual material and equipment, as agreed by IOM.

The Contractor shall submit within 7 (seven) calendar days after receipt of notice of termination, a written statement setting forth its proposal for an adjustment to the Contract Price to include only the incurred costs described in this clause. IOM shall review the proposal, and negotiate an equitable adjustment of the Contract Price. Other amounts paid in advance by IOM will be refunded by the Contractor within 7 (seven) days.

- 26.3 IOM may terminate this Agreement or any of the work under this Agreement at any time by immediate written notice to the Contractor, for causes which include but are not limited to:
- (a) The Contractor's violation of the terms and conditions of this Agreement;
  - (b) Contractor's default, failure or refusal to carry out order to remove and replace the unsound, incorrect or defective portion of the Works as per Article 14.5;
  - (c) Non-completion of the Works within the time agreed upon or the expiration of extension agreed upon, or delayed progress of the Works as stated in Article 6 or sub-standard work;
  - (d) Institution of insolvency or receivership proceedings involving the Contractor;
  - (e) If, in the judgment of IOM, the Contractor has engaged in corrupt or fraudulent practices in competing for and/or implementing the Agreement.

The written notice shall specify the Completion Rate as established by Article 6.2 upon termination, the effective date of termination, and any additional tasks that need to be performed including but not limited to those enumerated in Articles 26.1 and 26.2. Such termination shall be without prejudice to IOM's other rights and remedies in this Agreement, in law and in equity. Amounts paid in advance by IOM will be refunded by the Contractor within 7 (seven) days from the date of IOM's request.

26.4 Where IOM terminates this Agreement as per Article 26.3 above, all materials, plant, equipment and works financed under this Agreement shall be deemed to be the property of IOM, and the Contractor shall be liable for all the direct replacement cost incurred to IOM for the completion of the Works. The Contractor shall pay IOM the required amount within 30 (thirty) days from receipt of an invoice from IOM. The direct replacement cost shall be the difference between the remaining amount in Contract Price not paid to the Contractor upon termination including the Retention Amount (after the settlement of all remaining debts and obligations) and the actual cost spent by IOM for completion of the remainder of the Works plus overhead of 10% (ten percent) for additional administrative efforts of IOM.

- 26.5 Upon any termination, the Contractor shall waive any claims for damages including loss of anticipated profits on account thereof.
- 26.6 IOM may suspend the Agreement at any time, in whole or in part. In the event of suspension of this Agreement, IOM will specify the scope of activities and/or deliverables that shall be suspended in writing. All other rights and obligations of this Agreement shall remain applicable during the period of suspension. IOM will notify the Contractor in writing when the suspension is lifted and may modify the completion date. The Contractor shall not be entitled to claim or receive any additional payment or costs incurred during the period of suspension of this Agreement.

**27. Severability**

If any part of this Agreement is found to be invalid or unenforceable, that part will be severed from this Agreement and the remainder of the Agreement shall remain in full force.

**28. Entire Agreement**

This Agreement including its Annexes represents the entire agreement between the Parties and supersedes all prior agreements and understandings, if any, relating to the subject matter of this Agreement.

**29. Final Clauses**

29.1 This Agreement will enter into force upon signature by both Parties. It will remain in force until completion of all obligations of the Parties under this Agreement unless terminated earlier in accordance with the Article on Termination.

29.2 Except as provided under Article 7 above, any change to the terms and conditions detailed herein shall be documented in a written amendment to this Agreement.

**30. Special Provisions (Optional)**

Due to the requirements of the Donor financing the Project, the Contractor shall agree and accept the following provisions:

[Insert all donor requirements which must be flowed down to IOM’s implementing partners and subcontractors. In case of any doubt, please contact LEGContracts@iom.int]

Signed in duplicate in English, on the dates and at the places indicated below.

*For and on behalf of*  
The International Organization for  
Migration

*For and on behalf of*  
[Name of Contractor]

Signature

Signature

---

Name:  
Position:  
Date:  
Place:

---

Name:  
Position:  
Date:  
Place:

## SECTION 7: BIDDING FORMS

**Form A: Bid Confirmation**

**Form B: Checklist**

**Form C: Bid Submission**

**Form D: Bidder Information**

**Form E: Joint Venture / Consortium / Association Information**

**Form F: Eligibility and Qualification**

**Form G: Technical Bid**

**Form H: Price Schedule**

### FORM A: BID CONFIRMATION

Please acknowledge receipt of this ITB by completing this form and returning it by email to the address, and by the date specified, in the Letter of Invitation.

To:

Email:

From:

Subject

ITB reference

Check the appropriate box	Description
<input type="checkbox"/>	<b>YES</b> , we intend to submit a bid.
<input type="checkbox"/>	<b>NO</b> . We are unable to submit a competitive offer for the requested goods/works/services at the moment

If you selected NO above, please state the reason(s) below

Check applicable	Description
<input type="checkbox"/>	The requested goods/services are not within our range of supply
<input type="checkbox"/>	We are unable to submit a competitive offer for the requested products at the moment
<input type="checkbox"/>	The requested products are not available at the moment
<input type="checkbox"/>	We cannot meet the requested specifications
<input type="checkbox"/>	We cannot offer the requested type of packing
<input type="checkbox"/>	We can only offer FCA prices
<input type="checkbox"/>	The information provided for bidding purposes is insufficient
<input type="checkbox"/>	Your ITB is too complicated
<input type="checkbox"/>	Insufficient time is allowed to prepare a bid
<input type="checkbox"/>	We cannot meet the delivery requirements
<input type="checkbox"/>	We cannot adhere to your terms and conditions e.g. payment terms, request for performance security, etc.. Please provide details below.
<input type="checkbox"/>	Sustainability criteria/requirements are too stringent (if applicable)
<input type="checkbox"/>	We do not export
<input type="checkbox"/>	We do not sell to the UN

<input type="checkbox"/>	Your volume is too small and does not meet our order quantity
<input type="checkbox"/>	Our production capacity is currently full
<input type="checkbox"/>	We are closed during the holiday season
<input type="checkbox"/>	We had to give priority to other clients' requests
<input type="checkbox"/>	We do not sell directly but through distributors
<input type="checkbox"/>	We have no after-sales service available
<input type="checkbox"/>	The person handling the bids is away from the office
<input type="checkbox"/>	Other (please provide reasons below):
Further information: <a href="#">Click or tap here to enter text.</a>	
<input type="checkbox"/>	We would like to receive future ITBs for this type of goods
<input type="checkbox"/>	We don't want to receive ITBs for this type of goods

Questions to the bidder concerning the reasons for NO BID should be addressed to IOM phone +679 9987401 or [shkumar@iom.int](mailto:shkumar@iom.int)

#### **FORM B: CHECKLIST**

This form serves as a checklist for preparation of your bid. Please complete the returnable bidding forms in accordance with the instructions and return them as part of your bid submission: No alteration to the format of forms shall be permitted and no substitution shall be accepted.

Before submitting your bid, please ensure compliance with the instructions in Section 2: Instructions to Bidders and Section 3: Data Sheet.

#### **Technical bid:**

<b>Have you duly completed all the returnable bidding forms?</b>	
▪ Form C: Bid Submission	<input type="checkbox"/>
▪ Form D: Bidder Information	<input type="checkbox"/>
▪ Form E: Joint Venture/Consortium/Association Information	<input type="checkbox"/>
▪ Form F: Eligibility and Qualification	<input type="checkbox"/>
▪ Form G: Technical Bid/Bill of Quantities	<input type="checkbox"/>
<b>Have you provided the required documents to establish compliance with the evaluation criteria in Section 4?</b>	<input type="checkbox"/>
<b>Have you provided the required documents in support of Form D: Bidder Information?</b>	<input type="checkbox"/>

#### **Price Schedule:**

▪ Form H: Price Schedule	<input type="checkbox"/>
--------------------------	--------------------------



**FORM C: BID SUBMISSION**

Name of bidder:	Click or tap here to enter text.	Date:	Click or tap to enter a date.
ITB reference:	Click or tap here to enter text.		

We, the undersigned, offer to supply the goods and related services required for IOM in accordance with your Invitation to Bid No. [Click or tap here to enter text.](#) We hereby submit our bid, which includes this Technical Bid and Price Schedule.

The total price of our bid, excluding any discounts offered below is: Insert amount in words and figures, indicating amount(s) and respective currency(ies) (by lots if applicable) .

The discounts offered and the methodology of their application are:

- **Discounts:** If our bid is accepted, the following discounts shall apply Specify in detail each discount offered and the specific item of the Schedule of Requirement to which it applies, including if applicable discounts for accelerated payment.
- **Methodology of application of the discounts:** The discounts shall be applied using the following method: Specify in detail the method that shall be used to apply the discounts

**BIDDER’S DECLARATION OF CONFORMITY<sup>1</sup>**

Yes	No	
<input type="checkbox"/>	<input type="checkbox"/>	On behalf of the Supplier, I hereby represent and warrant that neither the Supplier, nor any person having powers of representation, decision-making or control over it or any member of its administrative, management or supervisory body, has been the subject of a final judgement or final administrative decision for one of the following reasons: bankruptcy, insolvency or winding-up procedures; breach of obligations relating to the payment of taxes or social security contributions; grave professional misconduct, including misrepresentation, fraud; corruption; conduct related to a criminal organisation; money laundering or terrorist financing; terrorist offences or offences linked to terrorist activities; child labour and other trafficking in human beings, any discriminatory or exploitative practice, or any practice that is inconsistent with the rights set forth in the Convention on the Rights of the Child or other prohibited practices; irregularity; creating or being a shell company.
<input type="checkbox"/>	<input type="checkbox"/>	On behalf of the Supplier, I further represent and warrant that the Supplier is financially sound and duly licensed.
<input type="checkbox"/>	<input type="checkbox"/>	On behalf of the Supplier, I further represent and warrant that the Supplier has adequate human resources, equipment, competence, expertise and skills necessary to complete the contract fully and satisfactorily, within the stipulated completion period and in accordance with the relevant terms and conditions.
<input type="checkbox"/>	<input type="checkbox"/>	On behalf of the Supplier, I further represent and warrant that the Supplier complies with all applicable laws, ordinances, rules and regulations.
<input type="checkbox"/>	<input type="checkbox"/>	On behalf of the Supplier, I further represent and warrant that the Supplier will in all circumstances act in the best interests of IOM.
<input type="checkbox"/>	<input type="checkbox"/>	On behalf of the Supplier, I further represent and warrant that no official of IOM or any third party has received from, will be offered by, or will receive from the Supplier any direct or indirect benefit arising from the contract.

<sup>1</sup> This form is mandatory to fill in and sign by every vendor who submits quotation

Yes	No	
<input type="checkbox"/>	<input type="checkbox"/>	On behalf of the Supplier, I further represent and warrant that the Supplier has not misrepresented or concealed any material facts during the contracting process.
<input type="checkbox"/>	<input type="checkbox"/>	On behalf of the Supplier, I further represent and warrant that the Supplier will respect the legal status, privileges and immunities of IOM as an intergovernmental organization.
<input type="checkbox"/>	<input type="checkbox"/>	On behalf of the Supplier, I further represent and warrant that neither the Supplier nor any persons having powers of representation, decision-making or control over the Supplier or any member of its administrative, management or supervisory body are included in the most recent Consolidated United Nations Security Council Sanctions List (the "UN Sanctions List") or are the subject of any sanctions or other temporary suspension. The Supplier will immediately disclose to IOM if it or they become subject to any sanction or temporary suspension.
<input type="checkbox"/>	<input type="checkbox"/>	On behalf of the Supplier, I further represent and warrant that the Supplier does not employ, provide resources to, support, contract or otherwise deal with any person, entity or other group associated with terrorism as per the UN Sanctions List and any other applicable anti-terrorism legislation.
<input type="checkbox"/>	<input type="checkbox"/>	On behalf of the Supplier, I further represent and warrant that, the Supplier will apply the highest ethical standards, the principles of efficiency and economy, equal opportunity, open competition and transparency, and will avoid any conflict of interest.
<input type="checkbox"/>	<input type="checkbox"/>	On behalf of the Supplier, I further represent and warrant that the Supplier undertakes to comply with the Code of Conduct, available at <a href="https://www.ungm.org/Public/CodeOfConduct">https://www.ungm.org/Public/CodeOfConduct</a> .
<input type="checkbox"/>	<input type="checkbox"/>	It is the responsibility of the Supplier to inform IOM immediately of any change to the information provided in this Declaration.
<input type="checkbox"/>	<input type="checkbox"/>	On behalf of the Supplier I certify that I am duly authorized to sign this Declaration and on behalf of the Supplier I agree to abide by the terms of this Declaration for the duration of any contract entered into between the Supplier and IOM.
<input type="checkbox"/>	<input type="checkbox"/>	IOM reserves the right to terminate any contract between IOM and the Supplier, with immediate effect and without liability, in the event of any misrepresentation made by the Supplier in this Declaration.

Signature: \_\_\_\_\_

Name: \_\_\_\_\_

Title: \_\_\_\_\_

Date: \_\_\_\_\_

**FORM D: BIDDER INFORMATION**



**VENDOR INFORMATION SHEET**

Vendor No. \_\_\_\_\_  
Internal to IOM

Registered Vendor Name\*: \_\_\_\_\_

Other Names/Acronyms \_\_\_\_\_

Address\* \_\_\_\_\_

House No \_\_\_\_\_

Street Name \_\_\_\_\_

ZIP/Postal Code\* \_\_\_\_\_

City\* \_\_\_\_\_

Region\* \_\_\_\_\_

Country\* \_\_\_\_\_

**Contact Information**

Company Tel/Mobile: \_\_\_\_\_

Company Email: \_\_\_\_\_

Company Website: \_\_\_\_\_

Contact Person: \_\_\_\_\_

Contact Person Position: \_\_\_\_\_

- Industry Category\*:**
- |  |  |
|--|--|
| <input type="checkbox"/> 0100 - Commercial Vendors           | <input type="checkbox"/> 0500 - International Organizations - Non-UN |
| <input type="checkbox"/> 0200 - National CSOs                | <input type="checkbox"/> 0600 - UN entities                          |
| <input type="checkbox"/> 0300 - National Government Entities | <input type="checkbox"/> 0005 - Individual Consultant/Non-Staff      |
| <input type="checkbox"/> 0400 - International CSOs           |  |

- Business Type\*:**
- Direct Producer/Manufacturing
- Reseller/Distributor/Service Provider

**Provide Services/Goods Internationally\***  Yes  No

**Disability-inclusive\***  Yes  Not applicable

- Women-owned/controlled\***
- At least 51% women-owned/controlled
- Less than 51% women-owned/controlled
- Not applicable

Notes
All fields marked with * are mandatory. The form may be returned if mandatory fields are missing/incorrect or in the wrong format (esp. Zipcode).
Vendor Name - should match IDs or registration documents.
If there is insufficient space, please use the Other Information section

**Product Categories (check all applicable)\***

- |   |  |  |   |
|---|--|--|---|
| <input type="checkbox"/> Agriculture, Livestock and Fisheries | <input type="checkbox"/> Fuels and Derivatives             | <input type="checkbox"/> Legal and Investigation     | <input type="checkbox"/> Power Supply and Electric        |
| <input type="checkbox"/> Chemicals                            | <input type="checkbox"/> Furniture                         | <input type="checkbox"/> Logistics and Warehousing   | <input type="checkbox"/> Quality Control and Environment  |
| <input type="checkbox"/> Clothing and Luggage                 | <input type="checkbox"/> Hospitality, Events               | <input type="checkbox"/> Media and Printing          | <input type="checkbox"/> Security                         |
| <input type="checkbox"/> Construction                         | <input type="checkbox"/> Insurances                        | <input type="checkbox"/> Medical, Drugs and Pharma   | <input type="checkbox"/> Social and Humanitarian Services |
| <input type="checkbox"/> Consultancy and Contracted Services  | <input type="checkbox"/> IT and Communications             | <input type="checkbox"/> NFIs - Household and Camps  | <input type="checkbox"/> Tickets                          |
| <input type="checkbox"/> Finance and Administration           | <input type="checkbox"/> Land and Buildings                | <input type="checkbox"/> Office Equipment and Supply | <input type="checkbox"/> Tools and Machinery              |
| <input type="checkbox"/> Food and Beverage                    | <input type="checkbox"/> Learning, Training and Recreation | <input type="checkbox"/> Personal Care               | <input type="checkbox"/> Vehicles and Accessories         |

UNGM No. \_\_\_\_\_

UN Partner Portal Reference \_\_\_\_\_

Registration Date \_\_\_\_\_

<https://www.ungm.org/UNUser/Home>

<https://www.unpartnerportal.org>

Main Country of Operations (dd-mmm-yyyy)

Licensing Auth./Type \_\_\_\_\_ License No.: \_\_\_\_\_ Reg. Date: \_\_\_\_\_ Expiry Date: \_\_\_\_\_  
For additional licenses, please use the Other Information Section dd-mmm-yyyy dd-mmm-yyyy

**Partner Entities** (indicate if there are other relevant business partner accounts already registered in IOM. Format: Account Number-Name )

Same entity registered in another office \_\_\_\_\_

Parent company \_\_\_\_\_

Subsidiaries/Branches \_\_\_\_\_

**Other Information:**

\_\_\_\_\_

\_\_\_\_\_

\_\_\_\_\_

**FORM E: JOINT VENTURE/CONSORTIUM/ASSOCIATION INFORMATION**

Name of bidder:	Click or tap here to enter text.	Date:	Click or tap to enter a date.
ITB reference:	Click or tap here to enter text.		

To be completed and returned with your bid if the bid is submitted as a Joint Venture/Consortium/Association.

No	Name of Partner and contact information ( <i>address, telephone numbers, fax numbers, e-mail address</i> )	The proposed proportion of responsibilities (in %) and type of goods, works and/or services to be performed
1	Click or tap here to enter text.	Click or tap here to enter text.
2	Click or tap here to enter text.	Click or tap here to enter text.
3	Click or tap here to enter text.	Click or tap here to enter text.

<p><b>Name of leading partner</b></p> <p>(with authority to bind the JV, Consortium, and Association during the ITB process and, in the event a contract is awarded, during contract execution)</p>	Click or tap here to enter text.
---	----------------------------------

We have attached a copy of the below referenced document signed by every partner, which details the likely legal structure of and the confirmation of joint and severable liability of the members of the said joint venture:

Letter of intent to form a joint venture **OR**  JV/Consortium/Association agreement.

We hereby confirm that if the contract is awarded, all parties of the Joint Venture/Consortium/Association shall be jointly and severally liable to [Click or tap here to enter text](#) for the fulfilment of the provisions of the Contract.

Name of partner: \_\_\_\_\_ Name of partner: \_\_\_\_\_

Signature: \_\_\_\_\_ Signature: \_\_\_\_\_

Date: \_\_\_\_\_ Date: \_\_\_\_\_

Name of partner: \_\_\_\_\_ Name of partner: \_\_\_\_\_

Signature: \_\_\_\_\_ Signature: \_\_\_\_\_

Date: \_\_\_\_\_ Date: \_\_\_\_\_

**FORM F: ELIGIBILITY AND QUALIFICATION FORM**

Name of bidder:		Date:	
ITB reference:			

*If JV/Consortium/Association, to be completed by each partner.*

**History of Non- Performing Contracts**

<input type="checkbox"/> No non-performing contracts during the last 3 years			
<input type="checkbox"/> Contract(s) not performed in the last 3 years			
Year	Non- performed portion of contract	Contract Identification	Total Contract Amount (current value in US\$)
		Name of Client: Address of Client: Reason(s) for non-performance:	

**Litigation History** (including pending litigation)

<input type="checkbox"/> No litigation history for the last 3 years			
<input type="checkbox"/> Litigation History as indicated below			
Year of dispute	Amount in dispute. (state currency)	Contract Identification	Total Contract Amount (state currency)
		Name of Client: Address of Client: Matter in dispute: Party who initiated the dispute: Status of dispute: Party awarded if resolved:	

**Previous Relevant Experience**

Please list only previous similar assignments successfully completed in the last 3 years.

List only those assignments for which the bidder was legally contracted or sub-contracted by the Client as a company or was one of the Consortium/JV partners. Assignments completed by the bidder’s individual experts working privately or through other firms cannot be claimed as the relevant experience of the bidder, or that of the bidder’s partners or sub-consultants, but can be claimed by the Experts themselves in their CVs. The bidder should be prepared to substantiate the claimed experience by presenting copies of relevant documents and references if so requested.

Project name & Country of Assignment	Client & Reference Contact Details	Contract Value	Period of activity and status	Types of activities undertaken and role (Contractor, sub-contractor, or consortium member)

*Bidders may also attach their own Project Data Sheets with more details for assignments above.*

Attached are the Statements of Satisfactory Performance from the Top 3 (three) Clients or more.

**Financial Standing**

<b>Annual Turnover for the last 3 years</b>	Year	Currency	Amount
	Year	Currency	Amount
	Year	Currency	Amount
<b>Latest Credit Rating (if any), indicate the source and date.</b>			

<b>Financial information</b> (state currency)	<b>Historic information for the last 3 years</b>		
	Year 1	Year 2	Year 3
	<i>Information from Balance Sheet</i>		
Total Assets (TA)			
Total Liabilities (TL)			
Current Assets (CA)			
Current Liabilities (CL)			
	<i>Information from Income Statement</i>		
Total / Gross Revenue (TR)			
Profits Before Taxes (PBT)			
Net Profit			
Current Ratio (current assets/current liabilities)			

Attached are copies of the audited financial statements (balance sheets, including all related notes, and income statements) for the years required above complying with the following condition:

- a) Must reflect the financial situation of the bidder or party to a JV, and not a sister or parent companies;
- b) Historic financial statements must be audited by a certified public accountant.
- c) Historic financial statements must correspond to accounting periods already completed and audited. No statements for partial periods shall be accepted.



**FORM G: TECHNICAL BID**

Name of bidder:	Click or tap here to enter text.	Date:	Click or tap to enter a date.
ITB reference:	Click or tap here to enter text.		

Goods, works and/or services to be Supplied and Technical Specifications	Bidder's response				Comments
	Compliance with technical specifications		Delivery Date (confirm that you comply or indicate your delivery date)	Quality Certificate/Export Licenses, etc. (indicate all that apply and attach)	
	Yes, we comply	No, we cannot comply (indicate discrepancies)			
Pine Post 200mm dia - 4.5m					
cement 40 kg					
River Gravel					
Fine Sand					
Cemestik 4 ltr					
Deformed Bars 16mm					
Visqueen					
Clout Tack 40mm					
Standard 200mm Block					
Deformed Bars 12mm					
Deformed Bars 10mm					
Binding wire 25 kg					
150x25mm Boxing Timber					
100x50mm Boxing Timber					
wire nail 100mm					
wire nail 75mm					
wire nail 50mm					
R10 Bars					
cement 40 kg					
River Gravel					
Fine Sand					
Cemestik 4 ltr					
665 Mesh					

Visqueen					
100x50mm D/Dressed Door Frames - 6m					
Galvanized nail 100mm					
Galvanized nail 75mm					
Solid core door 2200x900mm					
Hollow core door 2100x1000mm					
Hollow core door 2100x900mm					
Hollow core door 2100x850mm					
100mm butt hinge					
Privacy Set					
Dead lock Lockwood					
40x10mm Doorstop					
Powder coated aluminum framed egress					
door with glazing complete with locks					
Powder coated Aluminum frames with carriers					
Louvre blades and fixed glass					
200mm Standard Block					
200mm Bond Beam					
150mm standard block					
150mm Bond Beam					
cement					
fine sand					
River Gravel					
Deformed Bars 12mm					
Deformed Bars 16mm					
cement 40 kg					
River Gravel					
Fine Sand					

Deformed Bars 10mm					
Deformed Bars 16mm					
Deformed Bars 20mm					
200 X50mm Rafters - 6m					
200 X50mm Bottom Chord - 6m					
100x50mm Timber truss -6m					
200 X 50mm Timber Ridge board -6m					
75x50mm Timber Purlins - 6m					
280 x 28mm D/Dressed Fascia Board -6m					
50x50mm Ceiling Noggin - 6m					
Pryda Strapping 30m					
Color bond Ridge Cap					
26g Corrugated trimdeck roofing iron					
Double sided sisalation					
Roof screws type 17					
M12 bolt & nut 150mm					
Down pipe 150mm - 6m					
Down pipe clip					
150mm pvc bend					
Roof & gutter silicone					
Vent cowl 50mm					
Panel pin					
Galvanised nail 100mm					
Galvanised nail 75mm					
Galvanised nail 50mm					
plyboard 6mm					
150x50mm collar tie timber - 6m					

6mm gable end plate with holes					
Colorbond gutter					
Gutter Nozzle					
Clout Tack nail - 40mm					
Gutter strap - 2m					
M12 bolt & nut 150mm for splice					
50x50mm Ceiling Nodgging - 6m					
plyboard 6mm					
Towerbolt 100mm					
Panel pin					
Galvanised nail 100mm					
Toilet Pan					
Toilet Cistern					
Toilet seat w/ cover - black					
Toilet Roll holder					
Double bowl stainless steel sink					
shower cubicle complete set					
Vanity Hand Basin complete					
shower rose with arm					
Flexible hose 400mm					
Stop cock 15mm					
Floor grating 80mm					
swivel tap for kitchen sink					
15mm Pipe					
15mm Plain Socket					
15mm Faucet Socket					
15mm 'T' Junction					
15mm elbow					
50mm PVC Pipe					
Combination S & P Trap					
50mm Plain Socket					
50mm elbow					

50mm Faucet Socket					
50mm ' T' Junction					
150mm U PVC Pipe					
150mm Plain socket					
150mm elbow 90°					
150mm ' T' Junction					
pvc Glue 1000ml					
80mm Grab rail for disable toilet					
150mm Terminal vent					
150mm gully trap					
Mounting block					
Single switch					
Double GPO 10 amps					
Single GPO 10 amps					
weatherproof GPO IP53					
No. 2 cable clip					
Power point wire					
Light wire					
Switch wire					
36watts Fluorescent weatherproof luminaire					
with led 24 watts Fluorescent tubes					
36watts Fluorescent luminaire w / Prismatic					
Difusser with led 24 watts Fluorescent tubes					
18watts Fluorescent luminaire w / Prismatic					
Difusser with led 11 watts Fluorescent tubes					
weatherproof					
36watts Fluorescent luminaire w / Battery pk					
with led 24 watts Fluorescent tubes					
10 watts non maintained emergency exit					

running man single exist sign					
LED Flood Light 50 watts					
25mm saddle					
25mm conduit					
16mm highdrawn wire					
No.1 aerial clamp					
FEA nut & bolt					
Entry box					
20mm conduit					
20mm saddle					
20mm adaptor locknut					
6mm pvc red wire					
6mm pvc black wire					
6mm pvc green wire					
Earth clip					
Earth rod					
10A ELCB with cover					
16A ELCB with cover					
Two meter board					
5/32 machine screw & nut					
Exterior Undercoat 10 ltr					
Exterior Painting 20 ltr					
Interior Undercoat 10 ltr					
Interior Painting 20 ltr					
door & frames 20 ltr					
Fascia boards & posts 20 ltr					
Eaves Battens 20 ltr					
Ceiling 20 ltr					
Paint Brush 100mm					
Paint Brush 50mm					
Roller tray with handles					
Roller sleeves					
Thinner 4ltr					

Turpentine 4 ltr					
P80 Sand paper					
P100 Sand Paper					
Kitchen joinery including cabinets, Fitouts					
Admin office joinery and Library Room					
40mm Galvanised Pipe - 5.8m					
cutting disk 100mm					
grinding disk 100mm					
welding electrodes 12kg					
cement 40 kg					
River Gravel					
Fine Sand					
600X600mm Anti slip floor tiles					
Tile adhesive 20 kg					
Tile grout 10 kg					
D10 Bars					
cement					
Gravel					
fine sand					
100mm Block					
150mm standard block					
100mm standard block					
D12 Bars					
Cement					
Gravel					
Fine sand					
Binding wire 10 kg					
665 mesh 2.4x5.8m					
coral for soakage pits (2 different sites)					
Peforated pipe					
75X25mm Timber Shutters (6m)					
Shutter bracket					
Dyna bolt 100mm					
Galvanised nail 75mm					



Cement					
Gravel					
fine sand					
665 Mesh					

Other Related services and requirements <i>(based on the information provided in Section 5)</i>	Compliance with requirements		Details or comments on the related requirements
	Yes, we comply	No, we cannot comply <i>(indicate discrepancies)</i>	
e.g. Delivery Term			
Warranty			
Local Service Support			

**FORM H: PRICE SCHEDULE**

Name of bidder:	Click or tap here to enter text.	Date:	Click or tap to enter a date.
ITB reference:	Click or tap here to enter text.		

Bidders shall fill in these Price Schedule Forms in accordance with the instructions indicated.

**Bid Summary**

<b>Bidder's Total prices FCA (Price of goods FCA + Related Services if applicable)</b>	Insert amount and currency
<b>Bidder's Total prices CPT (Price of goods CPT + Related Services if applicable)</b>	Insert amount and currency
<b>Total Price of Goods FCA</b>	Insert amount and currency
<b>Total Price of Goods CPT</b>	Insert amount and currency
<b>Total Price of Related Services</b>	Insert amount and currency
<b>Freight Cost per 20/40 ft. container (if applicable)</b>	Insert amount and currency
<b>Customs clearance costs (if applicable)</b>	Insert amount and currency

**PRICES OF GOODS**

**PROJECT**

**Multi-purpose Evaluation      Date: 04/04/2024**

**Centre in Rokovoka Ra**

**SUBJECT**

**BILL OF QUANTITIES (Capacity: 150-200 people)**

ITEM	DESCRIPTION	QTY	UNIT	U/COST	TOTAL
<b>1.000</b>					
1.001	Pine Post 200mm dia - 4.5m	2.00	lgth		
1.002	cement 40 kg	270.00	bags		
1.003	River Gravel	47.00	m <sup>3</sup>		
1.004	Fine Sand	21.00	m <sup>3</sup>		
1.005	cemestik 4 ltr	10.00	gallon		
1.006	Deformed Bars 16mm	174.00	lgth		
1.007	Visqueen	10.00	roll		
1.008	Clout Tack 40mm	2.00	kg		
1.009	Standard 200mm Block	1,960.00	no.		
1.010	Deformed Bars 12mm	284.00	lgth		
1.011	Deformed Bars 10mm	285.00	lgth		
1.012	Binding wire 25 kg	5.00	coil		
1.013	150x25mm Boxing Timber	3.00	m <sup>3</sup>		
1.014	100x50mm Boxing Timber	3.00	m <sup>3</sup>		
1.015	wire nail 100mm	10.00	kg		
1.016	wire nail 75mm	10.00	kg		
1.017	wire nail 50mm	10.00	kg		
1.018	R10 Bars	83.00	lgth		
	<b>SUB-TOTAL</b>				
<b>2.000</b>					
2.001	cement 40 kg	323.00	bags		
2.002	River Gravel	58.00	m <sup>3</sup>		
2.003	Fine Sand	30.00	m <sup>3</sup>		
2.004	cemestik 4 ltr	8.00	gallon		
2.005	665 Mesh	36.00	sht		
2.006	Visqueen	10.00	roll		
	<b>SUB-TOTAL</b>				
<b>3.000</b>					
3.100	100x50mm D/Dressed Door Frames - 6m	10.00	lgth		
3.101	Galvanised nail 100mm	6.00	kg		
3.102	Galvanised nail 75mm	6.00	kg		
3.103	Solid core door 2200x900mm	3.00	no.		
3.104	Hollow core door 2100x1000mm	9.00	no.		
3.105	Hollow core door 2100x900mm	3.00	no.		
3.106	Hollow core door 2100x850mm	12.00	no.		
3.107	100mm butt hinge	81.00	no.		
3.108	Privacy Set	24.00	no.		
3.109	dead lock lockwood	1.00	no.		
3.110	40x10mm Door Stop	70.00	m		

3.111	Powdercoated alluminium framed egress				
3.112	door with glazing complete with locks	2.00	set		
	<b>SUB-TOTAL</b>				
<b>4.000</b>					
4.100	Powder coated Alluminium frames with carriers				
4.200	lourve blades and fixed glass				
	<b>SUB-TOTAL</b>				
<b>5.000</b>					
5.100	200mm Standard Block	1,908.00	block		
5.101	200mm Bond Beam	674.00	block		
5.102	150mm standard block	790.00	block		
5.103	150mm Bond Beam	395.00	block		
5.104	cement	267.00	bag		
5.105	fine sand	37.00	m <sup>3</sup>		
5.106	River Gravel	28.00	m <sup>3</sup>		
5.107	Deformed Bars 12mm	48.00	lgth		
5.108	Deformed Bars 16mm	171.00	lgth		
5.109	cement 40 kg	129.00	bags		
5.110	River Gravel	23.00	m <sup>3</sup>		
5.111	Fine Sand	12.00	m <sup>3</sup>		
5.112	Deformed Bars 10mm	258.00	lgth		
5.113	Deformed Bars 16mm	45.00	lgth		
5.114	Deformed Bars 20mm	114.00	lgth		
	<b>SUB-TOTAL</b>				
<b>6.000</b>					
6.100	200 X50mm Rafters - 6m	101.00	lgth		
6.101	200 X50mm Bottom Chord - 6m	15.00	lgth		
6.102	100x50mm Timber truss -6m	79.00	lgth		
6.103	200 X 50mm Timber Ridge board -6m	15.00	lgth		
6.104	75x50mm Timber Purlins - 6m	118.00	lgth		
6.105	280 x 28mm D/Dressed Fascia Board -6m	17.00	lgth		
6.106	50x50mm Ceiling Nodgging - 6m	290.00	lgth		
6.107	Pryda Strapping 30m	12.00	coil		
6.108	Colorbond Ridge Cap	90.00	m		
6.109	26g Corrugated trimdeck roofing iron	522.00	m <sup>2</sup>		
6.110	Double sided sisalation	522.00	m <sup>2</sup>		
6.111	Roof screws type 17	5,950.00	no.		
6.112	M12 bolt & nut 150mm	565.00	no.		
6.113	Down pipe 150mm - 6m	11.00	lgth		
6.114	Down pipe clip	33.00	no.		
6.115	150mm pvc bend	22.00	no.		
6.116	Roof & gutter silicone	12.00	tubes		
6.117	Vent cawl 50mm	8.00	no.		
6.118	Panel pin	8.00	kg		
6.119	Galvanised nail 100mm	8.00	kg		
6.120	Galvanised nail 75mm	8.00	kg		
6.121	Galvanised nail 50mm	8.00	kg		
6.122	plyboard 6mm	185.00	sht		

6.123	150x50mm collar tie timber - 6m	14.00	lgth		
6.124	6mm gable end plate with holes	33.00	no.		
6.125	Colorbond gutter	99.00	m		
6.126	Gutter Nozzle	11.00	no.		
6.127	Clout Tack nail - 40mm	10.00	kg		
6.128	Gutter strap - 2m	12.00	lgth		
6.129	M12 bolt & nut 150mm for splice	195.00	no.		
	<b>SUB-TOTAL</b>				
<b>7.000</b>					
7.100	50x50mm Ceiling Nodgging - 6m	19.00	lgth		
7.101	plyboard 6mm	20.00	sht		
7.102	Towerbolt 100mm	19.00	no.		
7.103	Panel pin	4.00	kg		
7.104	Galvanised nail 100mm	6.00	kg		
	<b>SUB-TOTAL</b>				
<b>8.000</b>					
8.101	Toilet Pan	8.00	no.		
8.102	Toilet Cistern	8.00	no.		
8.103	Toilet seat w/ cover - black	8.00	no.		
8.104	Toilet Roll holder	8.00	no.		
8.105	Double bowl stainless steel sink	1.00	no.		
8.106	shower cubicle complete set	2.00	no.		
8.107	Vanity Hand Basin complete	2.00	no.		
8.108	shower rose with arm	6.00	no.		
8.109	Flexible hose 400mm	8.00	no.		
8.110	Stop cock 15mm	16.00	no.		
8.111	Floor grating 80mm	5.00	no.		
8.112	swivel tap for kitchen sink	1.00	no.		
8.113	15mm Pipe	15.00	lgth		
8.114	15mm Plain Socket	20.00	no.		
8.115	15mm Faucet Socket	20.00	no.		
8.116	15mm 'T' Junction	15.00	no.		
8.117	15mm elbow	25.00	no.		
8.118	50mm PVC Pipe	8.00	lgth		
8.119	Combination S & P Trap	3.00	no.		
8.120	50mm Plain Socket	10.00	no.		
8.121	50mm elbow	10.00	no.		
8.122	50mm Faucet Socket	10.00	no.		
8.123	50mm ' T' Junction	10.00	no.		
8.124	150mm U PVC Pipe	17.00	lgth		
8.125	150mm Plain socket	10.00	no.		
8.126	150mm elbow 90°	8.00	no.		
8.127	150mm ' T' Junction	6.00	no.		
8.128	pvc Glue 1000ml	3.00	tin		
8.129	80mm Grab rail for disable toilet	2.00	set		
8.130	150mm Terminal vent	6.00	no.		
8.131	150mm gully trap	3.00	no.		
	<b>SUB-TOTAL</b>				

<b>9.000</b>					
9.101	Mounting block	50.00	pcs		
9.102	Single switch	10.00	pcs		
9.103	Double GPO 10 amps	27.00	pcs		
9.104	Single GPO 10 amps	6.00	pcs		
9.105	weatherproof GPO IP53	5.00	pcs		
9.106	No. 2 cable clip	3.00	pkts		
9.107	Power point wire	600.00	mtr		
9.108	Light wire	600.00	mtr		
9.109	Switch wire	400.00	mtr		
9.110	36watts Fluorescent weatherproof luminaire	31.00	pcs		
9.111	with led 24 watts Fluorescent tubes				
9.109	36watts Fluorescent luminaire w / Prismatic	38.00	pcs		
9.110	Difusser with led 24 watts Fluorescent tubes				
9.111	18watts Fluorescent luminaire w / Prismatic	5.00	pcs		
9.112	Difusser with led 11 watts Fluorescent tubes				
9.113	weatherproof				
9.114	36watts Fluorescent luminaire w / Battery pk	12.00	pcs		
9.115	with led 24 watts Fluorescent tubes				
9.116	10 watts non maintained emergency exit	3.00	pcs		
9.117	running man single exist sign				
9.118	LED Flood Light 50 watts	4.00	pcs		
9.119	25mm saddle	1.00	doz		
9.120	25mm conduit	2.00	lgth		
9.121	16mm highdrawn wire	20.00	mtr		
9.122	No.1 aerial clamp	2.00	pcs		
9.123	FEA nut & bolt	1.00	pcs		
9.124	Entry box	1.00	pcs		
9.125	20mm conduit	3.00	lgth		
9.126	20mm saddle	2.00	doz		
9.127	20mm adaptor locknut	1.00	pcs		
9.128	6mm pvc red wire	10.00	mtr		
9.129	6mm pvc black wire	10.00	mtr		
9.130	6mm pvc green wire	10.00	mtr		
9.131	Earth clip	1.00	pcs		
9.132	Earth rod	1.00	pcs		
9.133	10A ELCB with cover	1.00	pcs		
9.134	16A ELCB with cover	1.00	pcs		
9.135	Two meter board	1.00	pcs		
9.136	5/32 machine screw & nut	2.00	doz		
	<b>SUB-TOTAL</b>				
<b>10.000</b>					
10.101	Exterior Undercoat 10 ltr	10.00	gallon		
10.102	Exterior Painting 20 ltr	6.00	gallon		
10.103	Interior Undercoat 10 ltr	4.00	gallon		
10.104	Interior Painting 20 ltr	6.00	gallon		
10.105	door & frames 20 ltr	2.00	gallon		
10.106	Fascia boards & posts 20 ltr	2.00	gallon		
10.107	Eaves Battens 20 ltr	5.00	gallon		
10.108	Ceiling 20 ltr	6.00	gallon		

10.109	Paint Brush 100mm	20.00	no.		
10.110	Paint Brush 50mm	10.00	no.		
10.111	Roller tray with handles	10.00	no.		
10.109	Roller sleeves	10.00	no.		
10.110	Thinner 4ltr	2.00	no.		
10.111	Turpentine 4 ltr	2.00	no.		
10.112	P80 Sand paper	20.00	m		
10.113	P100 Sand Paper	20.00	no.		
	<b>SUB-TOTAL</b>				
<b>11.000</b>					
11.100	Kitchen joinery including cabinets, Fitouts	1.00			
11.101	Admin office joinery and Library Room	1.00			
	<b>SUB-TOTAL</b>				
<b>12.000</b>					
12.001	40mm Galvanised Pipe - 5.8m	8.00	lgth		
12.002	cutting disk 100mm	4.00	no.		
12.003	grinding disk 100mm	2.00	no.		
12.004	welding electrodes 12kg	1.00	pkt		
12.005	cement 40 kg	70.00	bags		
12.006	River Gravel	13.00	m <sup>3</sup>		
12.007	Fine Sand	8.00	m <sup>3</sup>		
	<b>SUB-TOTAL</b>				
<b>13.000</b>					
13.001	600X600mm Anti slip floor tiles	520.00	no.		
13.002	Tile adhesive 20 kg	33.00	bag		
13.003	Tile grout 10 kg	12.00	bag		
	<b>SUB-TOTAL</b>				
<b>14.000</b>					
14.001	D10 Bars	4.00	lgth		
14.002	cement	4.00	bags		
14.003	Gravel	1.00	m <sup>3</sup>		
14.004	fine sand	1.00	m <sup>3</sup>		
14.005	100mm Block	120.00	no.		
	<b>SUB-TOTAL</b>				
<b>15.000</b>					



15.001	150mm standard block	166.00	no.		
15.002	100mm standard block	210.00	no.		
15.003	D12 Bars	14.00	no.		
15.004	Cement	20.00	no.		
15.005	Gravel	5.00	m <sup>3</sup>		
15.006	Fine sand	3.00	m <sup>3</sup>		
15.007	Binding wire 10 kg	1.00	coil		
15.008	665 mesh 2.4x5.8m	2.00	sht		
15.009	coral for soakage pits (2 different sites)	10.00	heaps		
15.010	Peforated pipe	10.00	m		
	<b>SUB-TOTAL</b>				
<b>16.000</b>					
16.001	75X25mm Timber Shutters (6m)	120.00	lgth		
16.002	Shutter bracket	52.00	no.		
16.003	Dyna bolt 100mm	105.00	no.		
16.004	Galvanised nail 75mm	6.00	kg		
	<b>SUB-TOTAL</b>				
<b>17.000</b>					
17.001	Cement	60.00	bags		
17.002	Gravel	12.00	m <sup>3</sup>		
17.003	fine sand	6.00	m <sup>3</sup>		
17.004	665 Mesh	7.00	sht		
	<b>SUB-TOTAL</b>				
	<b>TOTAL Material Cost</b>				

**Prices for related services**

Item/lot	Description of the services	Quantity and physical unit (a) if applicable	Unit price (b) if applicable	Total price per service (a)x(b)
1.				
2.				
3.				
4.				
5.				
<b>Total Price of Related Services</b>				

	Item 3			
	Item 4			
	Item 5			
<b>FCA point(s) of delivery for offered products</b>	Item 1			
	Item 2			
	Item 3			
	Item 4			
<b>Shipment dimensions of offered products (Including package)</b>		<b>Gross weight</b>	<b>Total volume</b>	<b>Containers (if applicable)</b>
				<b>Number</b>
				<b>Size</b>
	Item 1			
	Item 2			
	Item 3			
	Item 4			
	Item 5			
	Total			

I, the undersigned, certify that I am duly authorized by IOM to sign this bid and bind [Click or tap here to enter text.](#)  
Should IOM accept this bid:

Name : \_\_\_\_\_

Title : \_\_\_\_\_

Date : \_\_\_\_\_

Signature : \_\_\_\_\_